



VERTICAL PIVOT GATE OPERATOR

INSTALLATION AND OPERATION MANUAL



CURBS

HIGH SECURITY

CRASH

RAILROAD

CUSTOM





VERTICAL PIVOT GATE OPERATOR INSTALLATION MANUAL

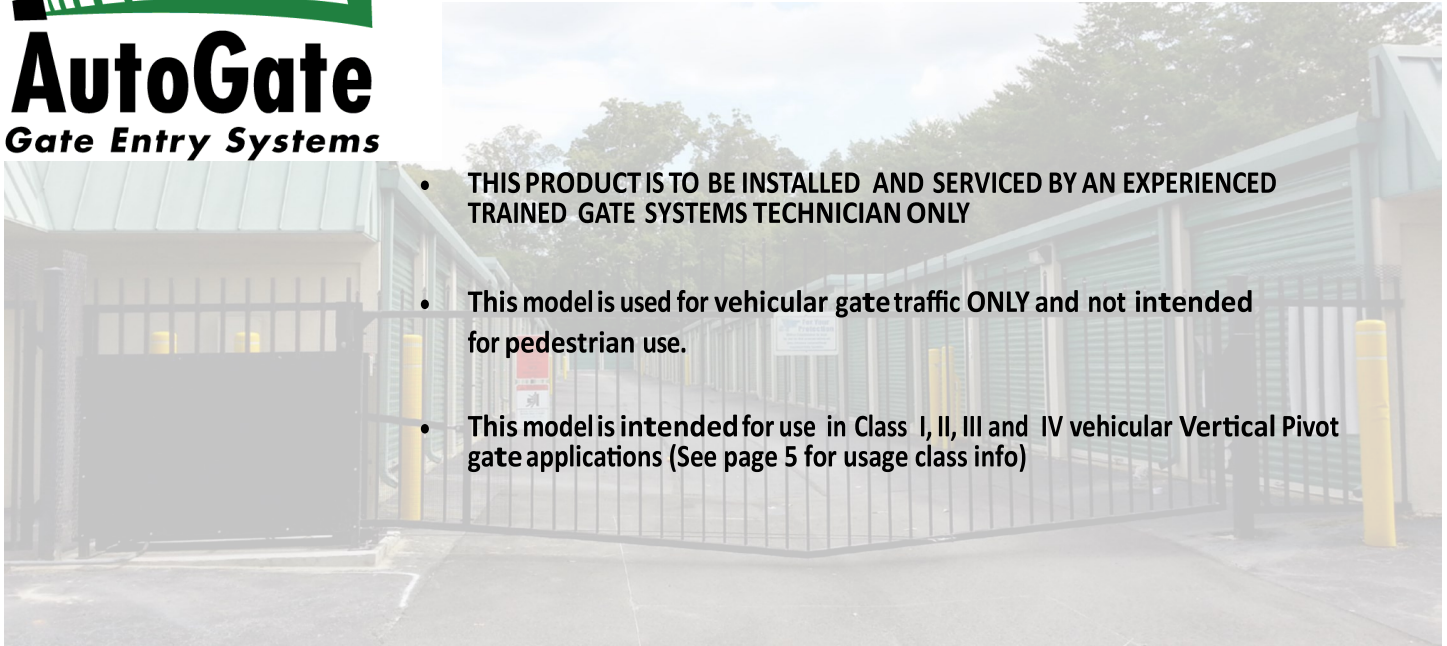

- THIS PRODUCT IS TO BE INSTALLED AND SERVICED BY AN EXPERIENCED TRAINED GATE SYSTEMS TECHNICIAN ONLY
- This model is used for vehicular gate traffic ONLY and not intended for pedestrian use.
- This model is intended for use in Class I, II, III and IV vehicular Vertical Pivot gate applications (See page 5 for usage class info)

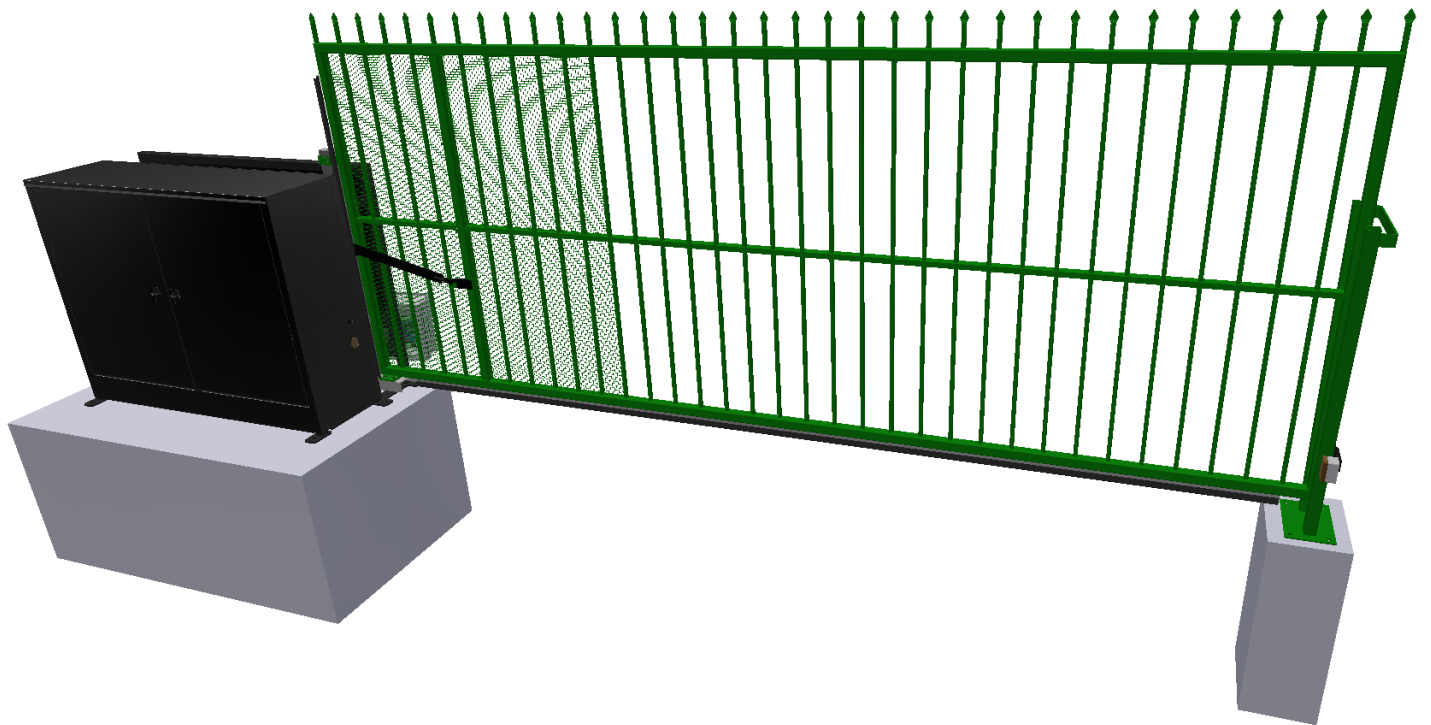

FULL SIZE MANUAL AVAIABLE TO DOWNLOAD AND PRINT AT WWW.AUTOGATE.COM



MODEL VPG2490

TABLE OF CONTENTS

INTRODUCTION

SECTION 1—SAFETY

SAFETY SIGN AND SYMBOL REVIEW.....	4
USAGE CLASS.....	5
UL325 ENTRAPMENT PROTECTION REQUIREMENTS...	5
GENERAL SAFETY INSTALLATION.....	6
SAFETY INSTALLATION INFORMATION UL325.....	7
GATE CONSTRUCTION INFORMATION ASTM F2200.....	8

SECTION 2-OPERATOR INFORMATION

TERMS.....	9
OPERATOR DETAILS.....	10
SPECIFICATIONS.....	11

SECTION 3-SITE

TYPICAL LAYOUTS & CONDUITS.....	12-13
PAD LAYOUTS.....	14
LEFT & RIGHT STANDARD PAD LAYOUTS.....	15

SECTION 4-RECEIVING

RECEIVING & UNLOADING GATE AND OPERATOR.....	16
ATTACHING GATE TO OPERATOR.....	17
LIFTING AND POSITIONING ASSEMBLED OPERATOR.....	18
MANUAL OPERATION.....	19
WINDBRACING.....	20
GATE GUARDS.....	21-23

SECTION 5-ELECTRICAL

ELECTRICAL.....	24
GROUNDING AND LIGHTENING PROTECTION.....	25
INSTALLING YOUR BATTERIES.....	25

SECTION 6-GENESIS BOARD

GENESIS BOARD	26
WIRING SCHEMATIC.....	27-28
GENESIS BOARD MENUS.....	29-37

SECTION 7 —ACCESSORY WIRING

NON-CONTACT ENTRAPMENT DEVICES.....	38
CONTACT ENTRAPMENT DEVICES.....	39
ARM OPEN EDGE INSTALLATION.....	40-41
ENTRAPEMENT PROTECTION DEVICE FUNCTIONAL CHARACTERISTICS.....	42
OPERATIONAL INPUTS.....	43
OPERATIONAL OUTPUTS.....	44
OPERATIONAL RELAYS.....	45
DUAL GATE.....	46
LPS-LIMIT POSITION SENSOR.....	46
Loop Rack.....	47

SECTION 8—GENESIS TROUBLESHOOTING

GENESIS FAQ'S.....	48-49
TOUBLESHOOTING THE GENESIS BOARD.....	50

SECTION 9—SERVICE & MAINTENANCE

RECOMMENDED MAINTENANCE.....	51
MAINTENANCE OPERATOR DETAILS.....	52
BELT CHANGING INSTRUCTIONS.....	53
SPRING CHANGING INSTRUCTIONS.....	54
BALANCING YOUR GATE.....	55
LEFT-HAND OPERATOR ASSEMBLY.....	56

INTRODUCTION

AutoGate Vertical Pivot Gate Systems (VPGs) are offered in many styles and aesthetic uniqueness that surpass our competition. Each system is quoted, designed, assembled and fabricated uniquely to each site. Nothing is cookie cutter at AutoGate except for our quality and commitment for delivering an exceptional product. In an industry of products that force the site or project to adjust to the limitation of a system, AutoGate seeks to adapt our systems to meet and exceed current, planned and future site conditions. VPGs are customizable for all site conditions:

- ◆ Varying road grades
- ◆ Curbs
- ◆ Space limitations
- ◆ Security requirements
- ◆ Weather conditions
- ◆ Aesthetic desires



These are true and consistent product differentiators.

Automatic Gate Operators can produce high levels of force, therefore, it is very important that all gate operator system installers and designers are fully aware of potential hazards that exist with an incorrectly installed or designed systems. The internal safety capabilities of a gate operator system are not enough to reduce the risk of injury. The operator is only one part of a properly installed system which when combined with all ASTM F2200 requirements and correctly installed approved entrapment devices will yield a completed UL 325, 7th edition/CSA 22.2 NO. 247-14 listed system that will not only provide convenience and security, but will be safer with a minimal risk of injury. This gate system should only be installed and serviced by a trained and preferably a Certified Gate Operator Installer. The following information contained in this manual along with the installation checklist provided will make you aware of potential areas that are of a safety concern. Disregarding any of the following may result in **SERIOUS INJURY OR DEATH!**

SECTION 1 — SAFETY

SAFETY SIGN AND SYMBOL REVIEW

When you see these Safety Symbols and Signal Words on the following pages, they will alert you to the possibility of Serious Injury or Death if you do not comply with the warnings. The hazard may come from something mechanical or from electric shock. Read the warnings carefully, they will alert you to the possibility of damage to your gate and/or the gate operator if you do not comply with the cautionary statements that accompany it. Read them carefully.

	WARNING
	ELECTRICAL
	CAUTION
	NOTE

IMPORTANT NOTE:

- **BEFORE** attempting to install, operate or maintain the operator, you must read and fully understand this manual and follow all safety instructions.
- **DO NOT** attempt repair or service of your gate operator unless you are an experienced Technician or a factory trained Service Technician.



WARNING: This product can expose you to chemicals including lead, which are known to the State of California to cause cancer or birth defects or other reproductive harm. For more information go to www.P65Warnings.ca.gov

USAGE CLASS

CLASS I - RESIDENTIAL VEHICULAR GATE OPERATOR

A vehicular gate operator (or system) intended for use in garages or parking areas associated with a residence of one-to four single families.

CLASS II - COMMERCIAL/GENERAL ACCESS VEHICULAR GATE OPERATOR

A vehicular gate operator (or system) intended for use in a commercial location or building such as a multi-family housing unit (five or more single family units), hotel, garages, retail store, or other buildings accessible by or servicing the general public.

CLASS III - INDUSTRIAL/LIMITED ACCESS VEHICULAR GATE OPERATOR

A vehicular gate operator (or system) intended for use in an industrial location or building such as a factory, loading dock area or other locations not accessible by or intended to service the general public.

CLASS IV - RESTRICTED ACCESS VEHICULAR GATE OPERATOR

A vehicular gate operator (or system) intended for use in a guarded industrial location or building such as an airport security area or other restricted access locations not servicing the general public, in which unauthorized access is prevented via supervision by security personnel.

UL 325 ENTRAPMENT PROTECTION REQUIREMENTS

VERTICAL PIVOT GATE OPERATOR

GATE OPERATOR ENTRAPMENT PROTECTION TYPES

TYPE A	Inherent (built into the operator) entrapment protection system
TYPE B1	Non-contact sensors such as photoelectric sensors/beams
TYPE B2	Contact sensors such as edge sensors

The same type of device shall not be used for both entrapment protection means. Use of a single device to cover both the opening and closing directions is in accordance with the requirement; however a single device is not required to cover both directions. This operator is provided with Type A. The installer is required to install additional entrapment protection devices in each entrapment zone.



WARNING

IMPORTANT SAFETY INSTRUCTIONS

WARNING—TO REDUCE THE RISK OF INJURY OR DEATH, READ AND FOLLOW ALL INSTRUCTIONS.

1. Never let children operate or play with gate controls. Keep the remote control away from children.
2. Always keep people and objects away from the gate. **NO ONE SHOULD CROSS THE PATH OF THE MOVING GATE.**
3. **DO NOT OPEN** the Gate Operator cabinet while gate is in motion
4. Test the gate operator monthly. The gate **MUST** reverse on contact with a rigid object or stop when an object activates the non-contact sensors. After adjusting the force or the limit of travel, retest the gate operator. Failure to adjust and retest the gate operator properly can increase the risk of injury or death.
5. Use the emergency release only when the gate is not moving.
6. **KEEP GATES PROPERLY MAINTAINED.** Read the user's manual. Have a qualified service person make repairs to gate hardware.
7. The entrance is for vehicles only. Pedestrians must use a separate entrance.
8. **SAVE THESE INSTRUCTIONS.**

GENERAL SAFETY INSTALLATION INFORMATION



WARNING!

INSTALL AND OPERATE THE GATE OPERATOR ONLY WHEN:

1. The operator is appropriate for the construction of the gate and the usage Class of the gate.
2. All areas of the moving vertical pivot gate panel from the bottom of the gate to the top of the gate or a minimum of 1.83 m (72 in) above grade, whichever is less, that pass by a fixed stationary object, and in the area of the adjacent fence that the gate covers during the travel of the gate, shall be designed, guarded or screened to prevent a 57 mm (2-1/4 in) diameter sphere from passing through such areas.
3. All exposed pinch points are eliminated or guarded
4. The installer has ensured “a)” through “h)” below are clearly understood and followed:
 - a) The operator is intended for installation only on gates used for vehicles. Pedestrians must be supplied with a separate access opening. The pedestrian access opening shall be designed to promote pedestrian usage. Locate the gate such that persons will not come in contact with the vehicular gate during the entire path of travel of the vehicular gate.
 - b) The gate must be installed in a location so that enough clearance is supplied between the gate and adjacent structures when opening and closing to reduce the risk of entrapment. Swinging gates shall not open into public access areas.
 - c) For gate operators utilizing Type D protection:
 - 1) The gate operator controls must be placed so that the user has full view of the gate area when the gate is moving,
 - 2) Automatic closing devices (such as a timer, loop sensor, or similar device) shall not be employed, and
 - 3) No other activation devices shall be connected.
 - d) Permanently mounted controls intended for user activation must be located at least 1.83 m (6 ft) away from any moving part of the gate and where the user is prevented from reaching over, under, around or through the gate to operate the controls.

Exception: Emergency access controls only accessible by authorized personnel (e.g. fire, police, EMS) may be placed at any location in the line-of-sight of the gate.

- e) The Stop and/or Reset button must be located in the line-of-sight of the gate. Activation of the reset control shall not cause the operator to start.
- f) A minimum of two (2) WARNING SIGNS shall be installed in the gate area. Each warning sign is to be visible by persons located on the side of the gate on which the placard is installed in the open or closed position.
- g) For gate operators utilizing non-contact sensors:
 - 1) See instructions on the placement of non-contact sensors for each type (**A, B1, B2**) of application,
 - 2) Care shall be exercised to reduce the risk of nuisance tripping, such as when a vehicle, trips the sensor while the gate is still moving, and
 - 3) One or more non-contact sensors shall be located where the risk of entrapment or obstruction exists, such as the perimeter reachable by a moving gate or barrier.
- h) For a gate operator utilizing contact sensors:
 - 1) One or more contact sensors shall be located where the risk of entrapment or obstruction exists, such as at the leading edge and trailing edge.
 - 2) One or more contact sensors shall be located at any pinch point of a vehicular vertical pivot gate.
 - 3) A hardwired contact sensor shall be located and its wiring arranged so that the communication between the sensor and the gate operator is not subjected to mechanical damage.

INSTALLATION INFORMATION PER UL 325

1. Vehicular gate systems provide convenience and security. Gate systems are comprised of many component parts. The gate operator is only one component. Each gate system is specifically designed for an individual application.
2. Gate operating system designers, installers and users must take into account the possible hazards associated with each individual application. Improperly designed, installed or maintained systems can create risks for the user as well as the bystander. Gate systems design and installation must reduce public exposure to potential hazards.
3. A gate operator can create high levels of force in its function as a component part of a gate system. Therefore, safety features must be incorporated into every design. Specific safety features include:
 - Contact Edge Sensors
 - Guards for Entrapment Areas
 - Photoelectric Sensors/Beams
 - Screen Mesh
 - Instructional and Precautionary Signage
4. Install the gate operator only when:
 - The operator is appropriate for the construction and the usage class of the gate.
 - All openings or leading edge of a Vertical Pivot gate operator that pass by any fixed stationary objects while traveling open or closing, shall be designed, guarded or screened to prevent a 2 ¼" (57mm) sphere from passing through or entering the protected area designed to prevent entrapment.
5. The operator system is intended for vehicular traffic only! Pedestrians must be supplied with a separate access opening. The pedestrian access opening shall be designed to promote pedestrian usage. Locate the pedestrian access (gate) such that persons will not come in contact with the vehicular gate during the entire path of travel of the vehicular gate.
6. The gate must be installed in a location so that enough clearance is supplied between the gate and adjacent structures when opening and closing to reduce the risk of entrapment.
7. The gate must be properly installed and work freely in both directions when disengaged from the gate operator drive system.
8. Controls intended for user activation must be located at least 6 feet (1.8 m) away from any moving part of the gate and where the user is prevented from reaching over, under, around or through the gate to operate the controls. Outdoor or easily accessible controls shall have a security feature to prevent unauthorized use.

Exception: Emergency access controls only accessible by authorized personnel (e.g. fire, police) may be placed at any location in the line-of-sight of the gate.
9. The Stop and/or Reset (if provided separately) must be located in the line-of-sight of the gate. Activation of the reset control shall not cause the operator to start.
10. A minimum of two (2) WARNING SIGNS shall be installed, one on each side of the gate where easily visible.
11. For a gate operator utilizing a non-contact sensor:
 - Reference owner's manual regarding placement of non-contact sensor for each type of application. See Install Entrapment Protection section.
 - Care shall be exercised to reduce the risk of nuisance tripping, such as when a vehicle trips the sensor while the gate is still moving.
 - One or more non-contact sensors shall be located where the risk of entrapment or obstruction exists, such as the perimeter reachable by a moving gate or barrier.
12. For a gate operator utilizing a contact edge sensor:
 - One or more contact sensors shall be located where the risk of entrapment or obstruction exists.
 - A hard wired contact sensor shall be located and its wiring arranged so the communication between the sensor and the gate operator is not subject to mechanical damage.

NOTE

At least two (2) independent protection means are required in each direction of travel. The term "means" refers to devices such as Type "A" (Inherent Limit/Position Sensor) or "B1" (Non-Contact sensors/beams) and "B2" (Contact Edge Sensors). It is the installers responsibility to identify and protect all entrapment zones.

Entrapment is the condition when an object or person is caught or held in a position that increases the risk of injury. An Entrapment "zone" is any area of the Vertical Pivot Gate system that entrapment can occur.

GATE CONSTRUCTION INFORMATION ASTM F2200

Vehicular gates should be installed in accordance with ASTM F2200: Standard Specification for Automated Vehicular Gate Construction. For a copy, contact ASTM directly at 610-832-9585 or www.astm.org.

GENERAL REQUIREMENTS

1. Gates shall be constructed in accordance with the provisions given for the appropriate gate type listed, refer to ASTM F2200 for additional gate types.
2. Gates shall be designed, constructed and installed to not fall over more than 45 degrees from the vertical plane, when a gate is detached from the supporting hardware.
3. Gates shall have smooth bottom edges, with vertical bottom edged protrusions not exceeding 0.50 inches (12.7 mm) when other than the exceptions listed in ASTM F2200.
4. The minimum height for barbed tape shall not be less than 8 feet (2.44 m) above grade and for barbed wire shall not be less than 6 feet (1.83 m) above grade.
5. An existing gate latch shall be disabled when a manually operated gate is retrofitted with a powered gate operator.
6. A gate latch shall not be installed on an automatically operated gate.
7. Protrusions shall not be permitted on any gate, refer to ASTM F2200 for Exceptions.
8. Gates shall be designed, constructed and installed such that their movement shall not be initiated by gravity when an automatic operator is disconnected, in accordance with the following:
 - Vehicular horizontal slide gate. Shall not result in continuous, unimpeded movement in either lineal direction of its travel.
 - Vehicular horizontal swing gate. Shall not result in continuous, unimpeded movement in either direction along the arc of its path of travel.
9. For pedestrian access in the vicinity of an automated vehicular gate, a separate pedestrian gate shall be provided. The pedestrian gate shall be installed in a location such that a pedestrian shall not come in contact with a moving vehicular access gate. A pedestrian gate shall not be incorporated into an automated vehicular gate panel.

SPECIFIC APPLICATIONS

1. Any non-automated gate that is to be automated shall be upgraded to conform to the provisions of this specification.
2. This specification shall not apply to gates generally used for pedestrian access and to vehicular gates not to be automated.
3. Any existing automated gate, when the operator re-

quires replacement, shall be upgraded to conform to the provisions of the required standard in effect at that time.

VEHICULAR VERTICAL PIVOT GATES

1. The following provisions shall apply to Class I, Class II and Class III vehicular Vertical Pivot gates:
2. All openings or leading edge of a Vertical Pivot gate operator that pass by any fixed stationary objects while traveling open or closing, shall be designed, guarded or screened to prevent a 2 ¼" (57mm) sphere from passing through or entering the protected area designed to prevent entrapment.
Exception: All other fixed stationary objects greater than 16" (406mm) from the moving gate frame shall not be required to comply with this section.
3. Horizontal and Vertical frame members of a gate shall be smooth and shall not include protrusions other than gate hardware.
4. All gates shall be designed with sufficient lateral stability to assure that the gate will enter a receiver guide.
5. Class IV vehicular horizontal Vertical Pivot gates shall be designed, constructed and installed in accordance with security related parameters specific to the application in question.

SECTION 2 — TERMS, STANDARDS AND SPECIFICATIONS

GLOSSARY OF IMPORTANT TERMS

Operator	The mechanical device designed to open and close (raise and lower) the gate/barrier
Operator Arm	The steel tubing member of the operator the gate is bolted to and lifts the gate/barrier
Slide Assembly	An adjustable mechanism located on the operator arm that the extension springs attach to and by adjusting up and or down adds or subtracts tension to balance the operation of opening and closing of the gate panel.
Hand	The orientation or direction in which a gate assembly faces. Gate operator manufacturers determine the “Hand” of the operator by standing on the Private side of the gate entrance looking out.
False Panel	The exterior covering of the operator that typically faces the public side of the installation and provides protection from the moving gate/barrier.
Transport/Maintenance Pin (T/M)	Used to secure the Operator Arm when there is no gate attached. Also is used as a safety lock open/closed device during service work.
RAD (Right Angle Drive)	½ HP Motor Drive utilizing locking worm gear technology. The motor shaft and output shaft are oriented at 90° from each other. This type of drive provides for smoother operation throughout the gate movement cycle and is not back drivable.
Manual Operation Release Lever	Used to disengage the Right Angle Drive (RAD) from the belt drive system to allow manual opening or closing of the gate panel.
LPS (Limit/Position Sensor)	An electronic position sensor mounted on the main pulley drive shaft that provides gate position feedback to the control board. This component provides two separate features: <ol style="list-style-type: none">1. Type “A” inherent entrapment protection which safeguards against obstructions that may block and stop the gate travel.2. Provides “open” & “close” limit positions
Genesis Control Board	The main circuit board that processes the inputs and outputs to control the overall operation of the gate.
Kick Panel	The panel under the doors to prevent anything from getting under the operator including hands, feet & rodents.
Gate Guard	The cage guard that protects the gate in the open position (up to 9') and prevents anyone from having access to that area.

OPERATOR DETAILS

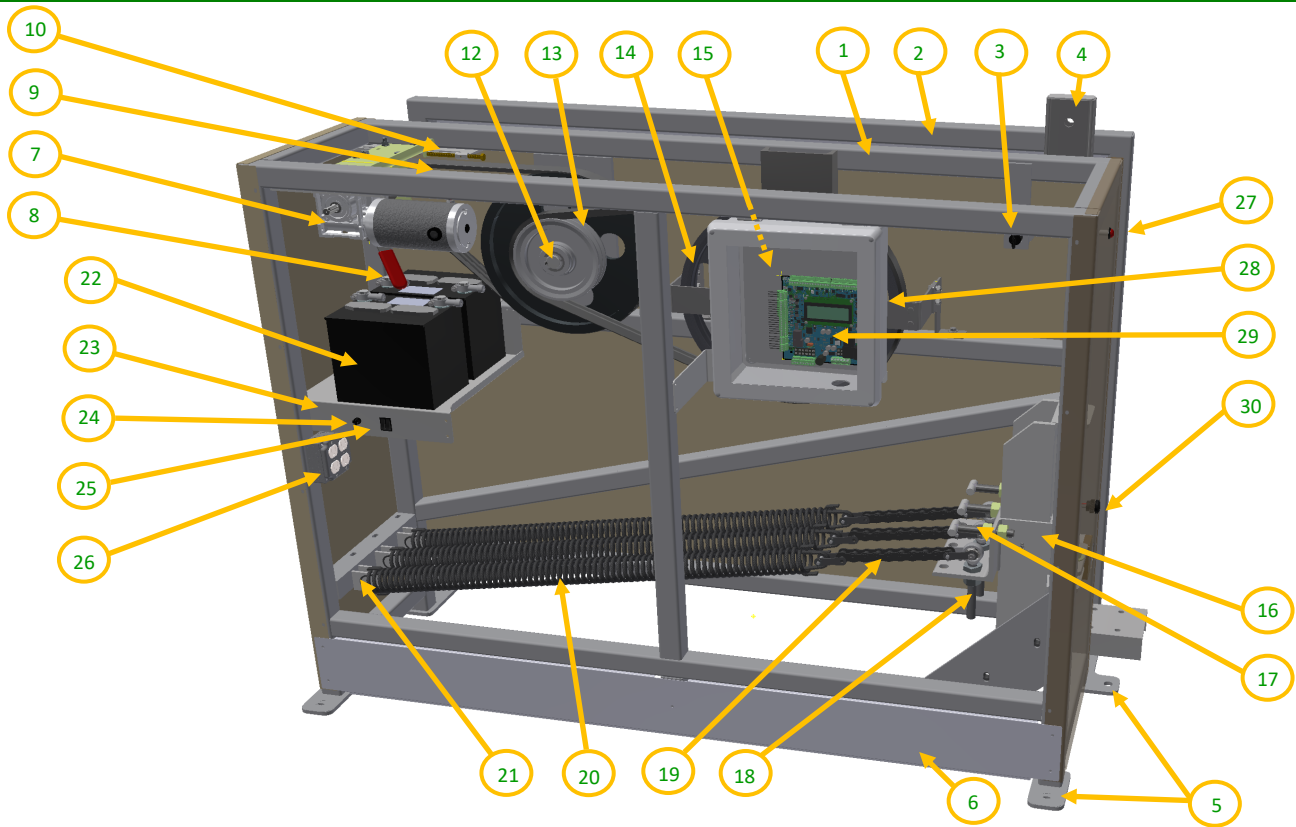

1	OPERATOR FRAME	Main operator frame, 2" sq. steel tube construction
2	THROAT	Area between the operator and false panel where the gate opens up
3	TRANSPORT/MAINTENANCE PIN (T/M)	Used for locking the arm in place with or without the gate attached
4	OPERATOR ARM	Main 2" x 4" steel tube where the gate attaches
5	STAINLESS STEEL FOOTPADS	No messy rusty footpads
6	KICK PANEL	Prevents access under the operator and helps keep debris out
7	24VDC 90° RIGHT ANGLE DRIVE MOTOR (RAD)	1/2hp Gear motor drive to ensure safe and smooth operation
8	MANUAL OPERATION REALEASE LEVER	Disengages the coupler and allows the gate to be raised by hand
9	MOTOR DRIVE BELTS	(3) High quality "A" Section cogged belts...
10	MOTOR DRIVE BELT TENSIONER	One shown, total of two
11	GATE BELT TENSIONER (Not shown, behind #12)	Allows you to tighten the belts (Not shown behind the Drive Pulley)
12	INTERMEADITE DRIVE PULLIES	Provides high torque to move the gate
13	GATE DRIVE BELTS	(2) High quality V-belts to move the gate
14	MAIN GATE DRIVE PULLEY	Provides high torque to move the gate
15	LIMIT/POSITION SENSOR (LPS) (behind #28)	Digital Sensor that sets the open and close locations of the gate
16	SLIDE ASSEMBLY	Adjust the balancing up or down on the threaded rod (not pictured)*
17	T-BOLT ASSEMBLY	Fine tuning of the balancing
18	CHAIN TENSIONING BOLT ASSEMBLY	Roller chain attaches here
19	#80 ROLLER CHAIN	Connects the springs to the Chain tension Bolt
20	SPRINGS (Qty. will vary on gate size and weight)	Depending on gate size & weight, you can have 2 to 8 springs
21	REAR SPRING BARS	Attaches the springs, Qty. will vary on the # of springs
22	BATTERIES ((2) required, not supplied)	Min. 7Ah batteries, recommend Group 24 100Amp Marine Starting
23	BATTERY TRAY/POWER SUPPLY (Under Battery tray)	Main Power Supply is mounted under the Battery Tray
24	3Amp AC Fuse	AC Supply fuse
25	AC/DC MAIN ON/OFF SWITCH	Turns on both the AC and DC power in one switch
26	INCOMING AC VOLTAGE JUNCTION BOX	Normally 120Vac, 240Vac compatible
27	FAULT LIGHT	Three flash modes: 1. Fault, 2: DC Power issue, 3: AC power issue
28	CONTROL BOX	Houses the Genesis control board and other accessory items
29	GENESIS CONTROL BOARD	State of the art control board with 4-line digital display
30	UL325 SIREN	Will be activate upon an UL fault
	* See Balancing Instructions for Slide details	



VERTICAL PIVOT GATE SYSTEM

MODEL VPG2490

SPECIFICATIONS

General Information

UL 325 7th Ed. Listed & CAN/CSA C22.2 No. 247-14 Listed Rated for Continuous Duty Cycling
Power Supply Options: 120VAC—Single Phase, 20 Amp Service. 240VAC—Single Phase, 20 Amp Service. Solar. Note: Extreme cold heat package requires an additional 15 Amp Service.
Batteries & Charging System: Built-in Battery Backup. Two 12v Batteries Required (Field Supplied). Recommended Batteries: Group 24, Sealed Marine Starting.
Gate Limit/Position Sensor (LPS): Combined Type “A” Entrapment protection. Open and Close Limit Position.
Open/Closing Speed: 8-10 seconds Std. Oversized (heavy Duty) gate speed of 12-15.
Shipping Weight: Typical VPG2490 Operator with 6’ high x 20’ long picket style gate = 1,500 - 1,800 lbs.
Warranty: Residential (5 years), Industrial/Commercial (3 years) from date of shipment on manufactured components workmanship. Purchased components and accessories are covered under their respective warranties. <i>(See full warranty for details)</i>
Optional Accessories: Solar Panels, Gear Motor Heater, Extreme Cold Package, MUTCD Reflective Tape, LED Warning lights, Audible Devices, and Emergency Access Systems. (SOS, Opticom, Click to Enter, Key Box/Switch, etc.)
Transport Maintenance Pin (T/M): used for transport, maintenance to negate movement of gate panel).

Motor & Drive System

RAD (Right Angle Drive): 1/2 HP, Gear Type, Right Angle Locking Worm Drive. Equipped with disengage lever for Manual Operation.
Multi Belt/High torque dual reduction system, Counter Balanced for smooth operation.

Operator

Construction: Frame - 2” Sq., 11 Ga. (.120). Mounting pads—304 SS. Skins - 18 Ga. Galvanneal.
Gate Mounting Hardware: 304 Stainless Steel.
Operator size: 68” Length, 53” Height, 30” Width.
Paint: Standard Color Operator: Black , powder coated. Spray applied colors are Commercial Coating 2-part High Solids Polyurethane. Standard Spray Color: Black. Custom colors include: White, Brown, Green, Gray. Consult factory for Specialty colors.

Genesis™ Control Board

Solid State coated programmable control board in an NEMA 4 electrical enclosure. (Tested to -40° F)
Security Breach Protection: Built in 24V brake when A/C or battery is present. Optional internal locking Solenoid mechanism.
Monitored Inputs: Open - 2 inputs, Close - 2 inputs with an (2) additional programmable inputs for Open or Close.
Programmable Inputs, Outputs, & Relays: The board has 2 programmable inputs, 2 programmable outputs, and 2 built in relays for configuration and integration.
Control Wiring: 16 & 18 Ga. Single conductor. Copper with electronic compression terminals tin-plated for max corrosion prevention.
Dual Gate Operation: Programing allows for dual gate operation and Sally-Port configuration.
Delayed Closing: Programmable from 0 - 90 seconds.
Preemptive Signal outputs: 1-5 seconds before gate moves.

Gate Construction

Gate Construction: 10’ - 20’ - 2” Sq., 11 Ga. (.120) Steel Tubing. Over 20’-2 1/2” Sq., 7 Ga. (.187) Aluminum Tubing.
Gate Lengths: 10’ - 25’ (Consult factor for over 25’) Gate Heights: 4’ - 8’ from pad grade. Consult factory for gates over 8’ high as they require special crating and freight arrangements.
Picket Construction: Steel-3/4” Sq. 18 Ga. Galvanized Tubing is standard. Aluminum-3/4” Sq. 1/8” wall is standard. Note: Contact factory for special sizes, spacing, and custom materials.
Chain Link Construction: 2 3/8” Sch. 40, 20 & 2” x .065” Galv. Steel Tubing 9 Ga. Galv. Fabric. (12’ up to 22’) 2 3/8” Sch. 80, 40 & 2” x 1/8” 6061 Alum. Tubing 9 Ga. Alum Fabric. (over 22’ to 25’)
Wind Bracing: Cable -75 mph design, 1/4” coated aircraft cable (16’ 20” gates). Rigid Masted - Gates over 20’ or certain heights and materials. Compliant with IBC Section 1609.6 Simplified Wind Load Method for 90 mph wind loading and the 150 mph hurricane wind loading are calculated for the “closed” position. Do not leave gates locked open in extreme wind conditions
Paint: Spray applied colors are Commercial Coating 2-part High Solids Polyurethane. Standard Spray Color: Black. Custom colors include: White, Brown, Green, and Gray. Consult Factory for Specialty colors. Powder coating available: Max length of 22’ and max height of 7’.

AutoGate, Inc. 7306 Driver Rd., Berlin Heights OH 44814 (800) 944-4283 www.AutoGate.com

SECTION 3 — TYPICAL LAYOUTS W/CONDUIT RECOMMENDATIONS

TYPICAL SINGLE GATE INSTALLATION (KEYPAD IN-FREE EXIT OUT)

LOOP DETAILS:

Typical size: 6' x 10'

Max width: 6' x 20'

Custom sizes available

Minimum 4' from the gate

TYPICAL TYPES:

- **Reversing:** reverses the gate
- **Free Exit:** Opens the gate
- **Arming:** Activates Access Controls
- **Shadow:** Holds gates open (Swing gates)
- **Close:** Closes a gate (normally Barrier Arms)

120 V POWER SUPPLY
COMMUNICATIONS

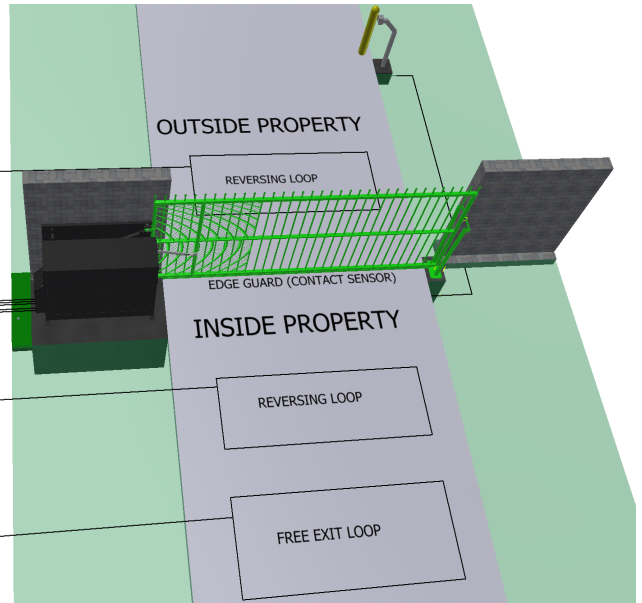

Typical conduit runs:

1. AC Power Supply (20 AMP Circuit)
2. Communication to office (if applicable)
3. Photoelectric Sensor (IFR BEAM) Low Voltage Power (if applicable under driveway)
4. Reversing Loop Homeruns
5. Free Exit Loop homerun (if applicable)
6. Keypad/card/phone signal & power (if applicable)
7. Gate to Gate Communications (Dual gate or Primary/Secondary system)
8. OPTION: 2nd 120Vac Outlet for Cabinet Heater

TYPICAL SINGLE GATE INSTALLATION (KEYPAD IN-KEYPAD OUT)

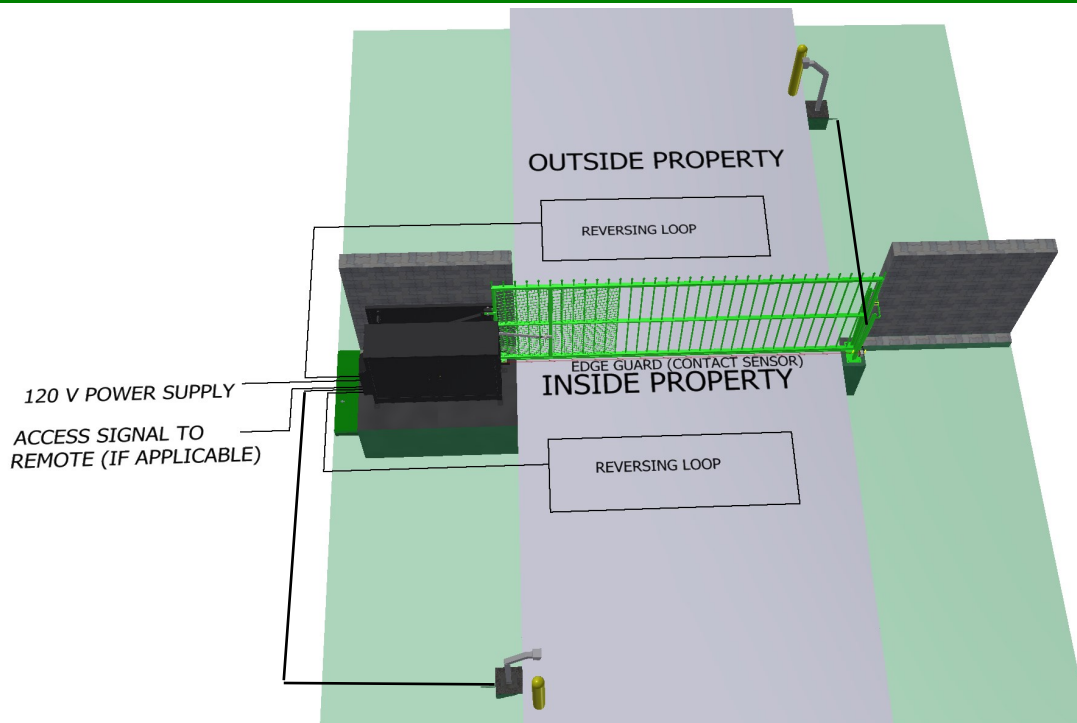

TYPICAL LAYOUTS W/CONDUIT RECOMMENDATIONS

TYPICAL PRIMARY/SECONDARY INSTALLATION

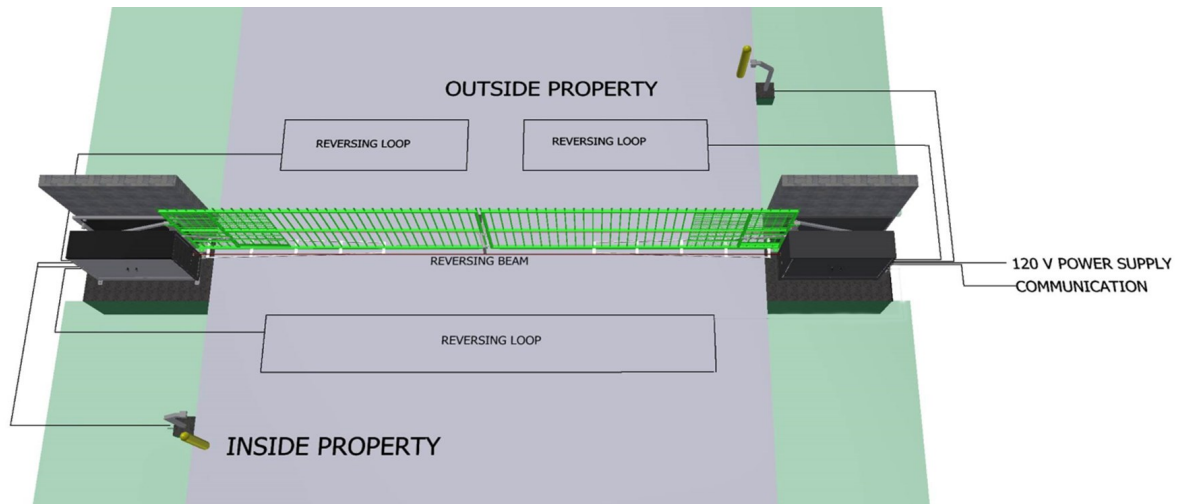

Typical conduit runs:

1. AC Power Supply (20 AMP Circuit)
2. Communication to office (if applicable)
3. Photoelectric Sensor (IFR BEAM) Low Voltage Power (if applicable under driveway))
4. Reversing Loop Homeruns
5. Free Exit Loop homerun (if applicable)
6. Keypad/card/phone signal & power (if applicable)
7. Gate to Gate Communications (Dual gate or Primary/Secondary system)
8. OPTION: 2nd 120Vac Outlet for Cabinet Heater

TYPICAL DUAL GATE INSTALLATION

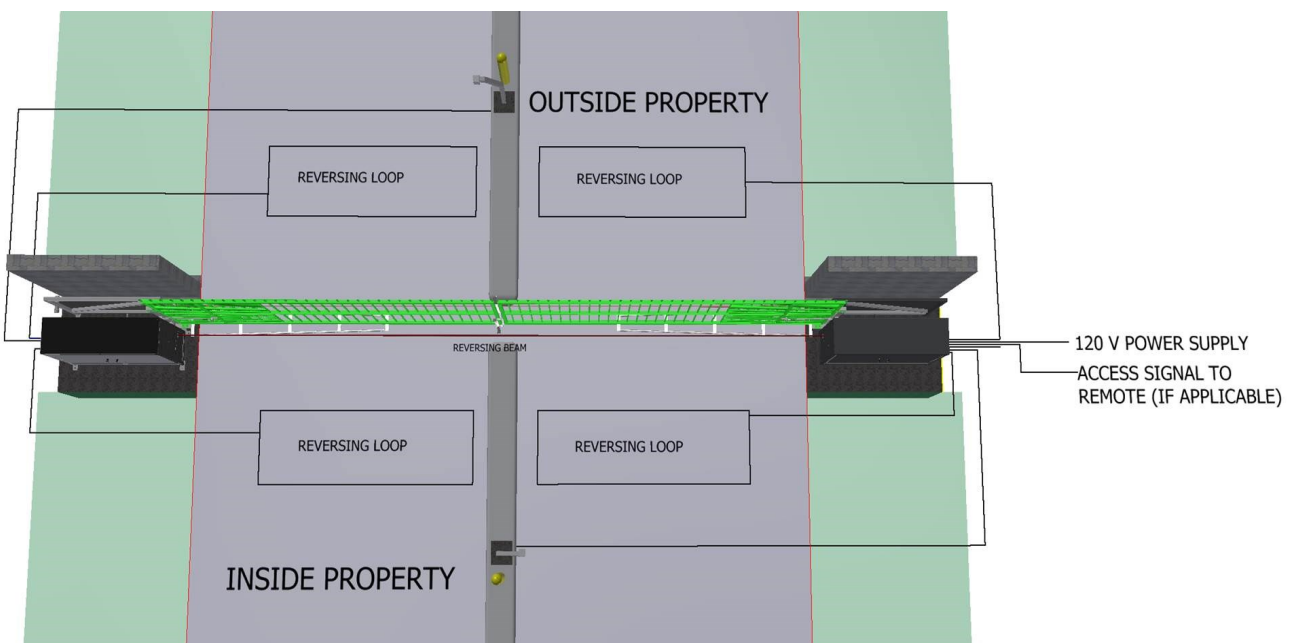

INSTALLING YOUR VERTICAL PIVOT GATE SYSTEM

TOOLS AND EQUIPMENT RECOMMENDATIONS

- ◆ Lifting Strap
- ◆ Hammer & Level
- ◆ Grease Gun, Lithium Grease
- ◆ Screwdriver Sets (Flat & Phillips)
- ◆ Electrical Tape, Wire Cutters/Strippers
- ◆ Misc. Electrical Connectors
- ◆ Chalk Line
- ◆ Multi-Meter (DCV & AMPS)
- ◆ Hammer Drill, 1/2 & 5/8 Bits
- ◆ Tape Measure
- ◆ 1/2" Drive Socket Set: 1/2", 9/16", 3/4", 15/16", 1-1/8"
- ◆ Open End Wrenches: 1/2", 9/16", 3/4", 15/16", 1-1/8"
- ◆ Batteries: (2) 12 VDC Group 24 Deep cycle marine starting

RECOMMENDED CONCRETE FOUNDATION OPTIONS

NOTE: Refer to customer site drawings for proper pad height. Normal height of most pads is top of grade or top of curb..

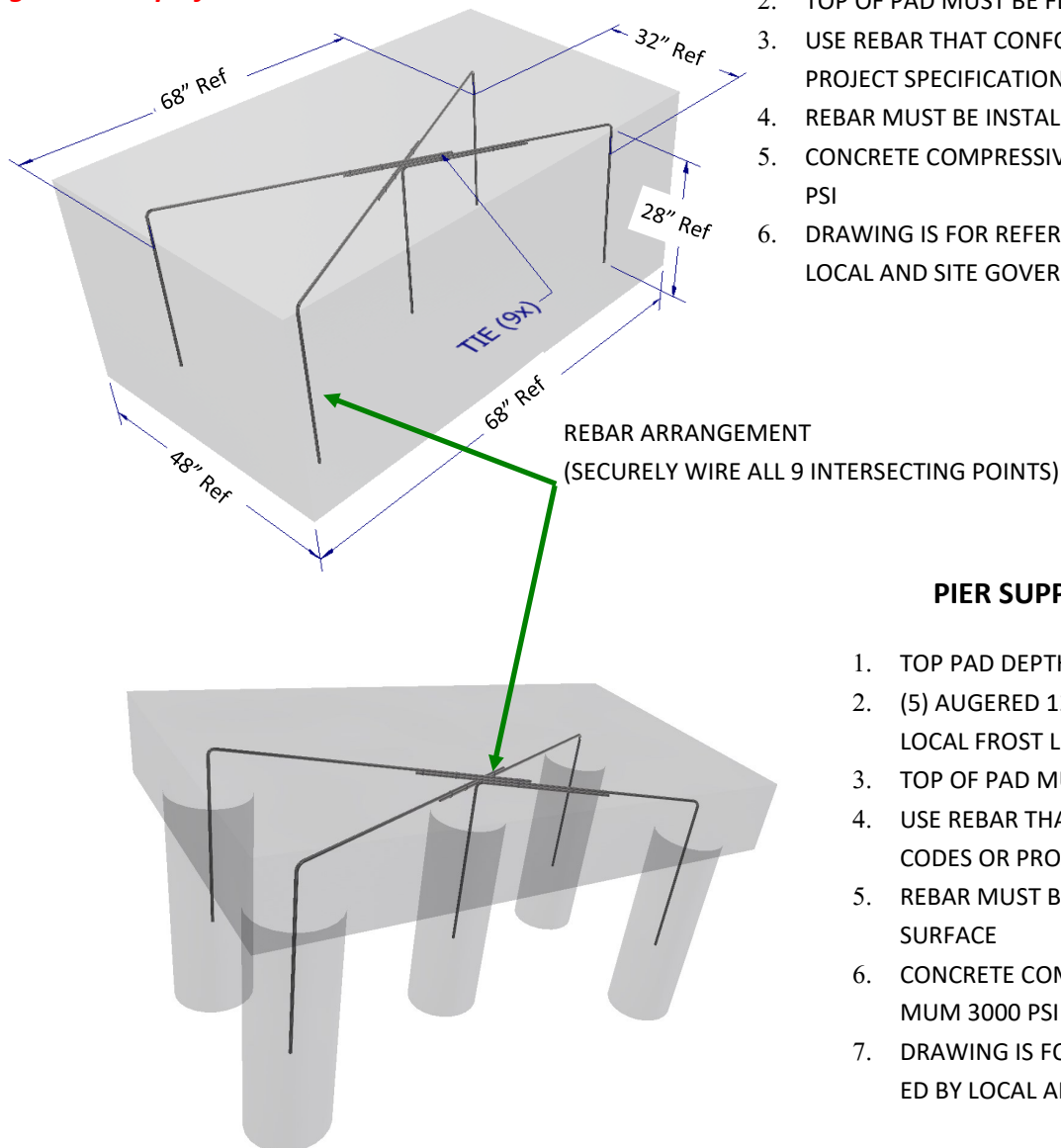

SOLID PAD OPTION

1. PAD DEPTH SHOULD BE BELOW LOCAL FROST DEPTH
2. TOP OF PAD MUST BE FLAT AND LEVEL
3. USE REBAR THAT CONFORMS WITH LOCAL CODES OR PROJECT SPECIFICATIONS
4. REBAR MUST BE INSTALLED 6"-8" BELOW TOP SURFACE.
5. CONCRETE COMPRESSIVE STRENGTH MINIMUM 3000 PSI
6. DRAWING IS FOR REFERENCE ONLY, SUPERCEDED BY LOCAL AND SITE GOVERNING CODES

PIER SUPPORTED PAD OPTION

1. TOP PAD DEPTH SHOULD BE 10"-12" THICK
2. (5) AUGERED 12"Ø HOLES SHOULD BE BELOW LOCAL FROST LINES
3. TOP OF PAD MUST BE FLAT AND LEVEL
4. USE REBAR THAT CONFORMS WITH LOCAL CODES OR PROJECT SPECIFICATIONS
5. REBAR MUST BE INSTALLED 6"-8" BELOW TOP SURFACE
6. CONCRETE COMPRESSIVE STRENGTH MINIMUM 3000 PSI
7. DRAWING IS FOR REFERENCE ONLY, SUPERCEDED BY LOCAL AND SITE GOVERNING CODES

LEFT AND RIGHT HAND STANDARD PAD & CONDUIT

LEFTHAND OPERATOR

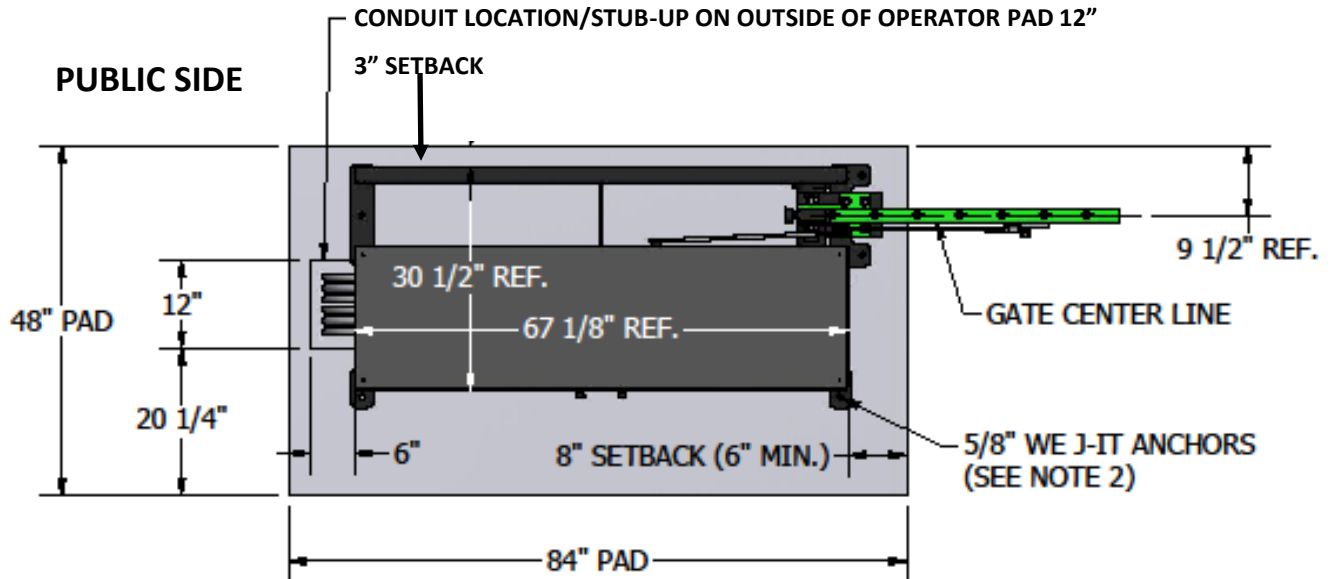

PRIVATE/SECURED SIDE

TYPICAL CONDUITS (Use 3/4" conduit or larger)

NOTES:

- 1) Pad Dimensions can vary per site
- 2) Leave at least 3" between Anchors and edge of pad
- 3) All pads must be level and below local frost line

- ◆ 120Vac, Minimum 20Amp Circuit
- ◆ Free Exit Loop(s)
- ◆ "Entrance" Keypad/Reader
- ◆ Office Communication
- ◆ "Exit" Keypad/Reader
- ◆ Reversing Beam
- ◆ Reversing Loop(s)
- ◆ Optional 2nd 120Vac Outlet for Cabinet Heater

RIGHTHAND OPERATOR

CONDUIT LOCATION/STUB-UP ON OUTSIDE OF OPERATOR PAD 12"

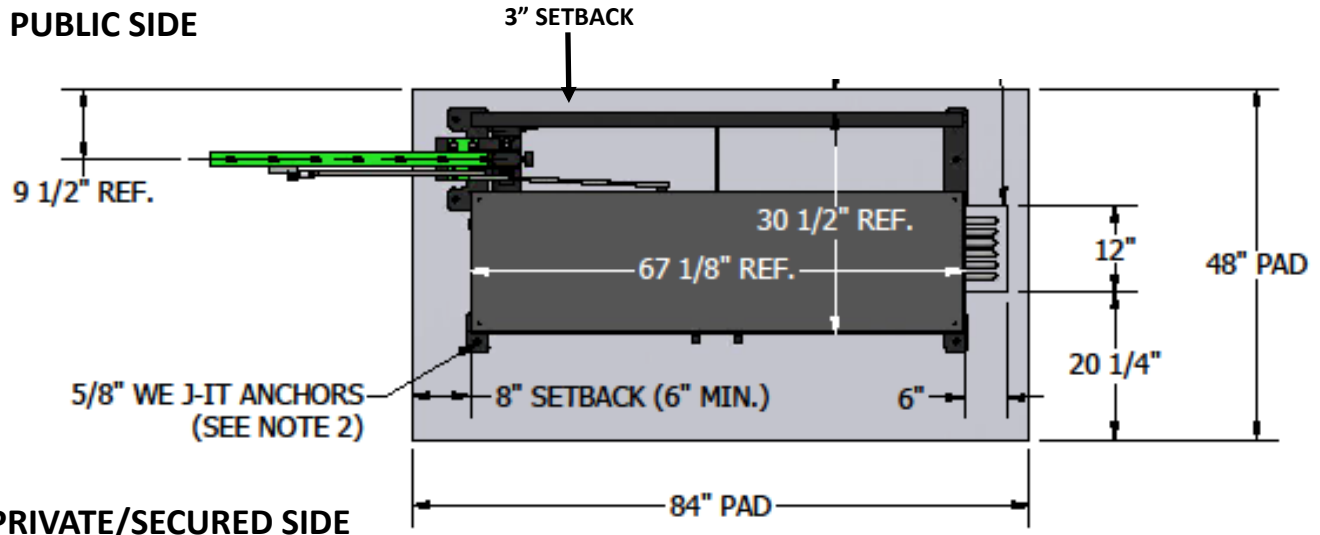

PRIVATE/SECURED SIDE

TYPICAL CONDUITS (Use 3/4" conduit or larger)

NOTES:

- 1) Pad Dimensions can vary per site
- 2) Leave at least 3" between Anchors and edge of pad
- 3) All pads must be level and below local frost line

- ◆ 120Vac, Minimum 20Amp Circuit
- ◆ Free Exit Loop(s)
- ◆ "Entrance" Keypad/Reader
- ◆ Office Communication
- ◆ "Exit" Keypad/Reader
- ◆ Reversing Beam
- ◆ Reversing Loop(s)
- ◆ Optional 2nd 120Vac Outlet for Cabinet Heater

SECTION 4—RECEIVING AND UNLOADING YOUR VERTICAL PIVOT GATE SYSTEM

Gate operator and gate can be delivered assembled but are commonly delivered in two separate crates. Crated operators are assembled and ready for the gate to be attached with supplied hardware.



CAUTION: ALWAYS INSPECT ALL ITEMS FOR DAMAGE BEFORE THE DRIVER LEAVES!

DOCUMENT ANY DAMAGE ON THE DELIVERY RECEIPT.

DO NOT DROP THE GATE OR THE OPERATOR FROM THE TRUCK!

Common Carrier Delivery Unloading Tips

- Always request a delivery service with lift gate delivery trucks (not available for “volume” shipments, (3) or more gates.
- Depending on what you are using to unload your system, make sure you have at least 2 guys (**More may be required**).
- Use the lift gate or a *fork lift* (or similar) to lower the operator
- Be sure to use leveling jacks (if available) to support weight of operator on tail lift
- **Do not stand under or near operator while lifting** Use “cut out” cardboard hole for lifting strap positioning

- Use a fork lift or similar device with a nylon lifting strap to off load the gate
- With lift gate in raised position gate can be positioned partially out of the truck
- *POSITION GATE SO THAT EXISTING CUT OUT FOR LIFTING IS JUST OUTSIDE THE TRUCK*
- **Do not stand under or near gate while lifting**

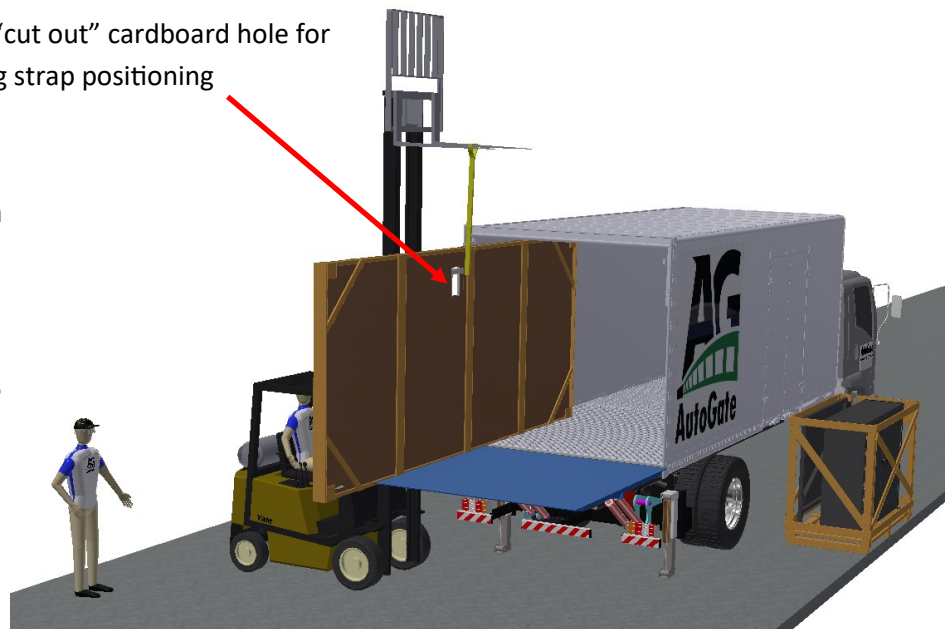

Assembled System Delivery

- Refer to page 18 “Lifting your Gate and Operator” for unloading and proper lifting tips.

ATTACHING YOUR GATE TO THE OPERATOR

Carefully remove Gate operator and gate from packaging. Locate the cabinet door keys hanging on the **Transport/Maintenance Pin (T/M)**. Any accessories and necessary fasteners are packaged inside the operator.



WARNING: DO NOT REMOVE TRANSPORT/MAINTENANCE PIN UNTIL GATE HAS BEEN BOLTED TO THE OPERATOR ARM AND THE OPERATOR IS SECURELY ANCHORED ACCORDING TO INSTRUCTIONS BELOW. OPERATOR ARM IS UNDER EXTREME TENSION LOAD AND REMOVING PIN COULD LEAD TO SERIOUS INJURY OR DEATH. IF AUTOGATE ATTACHED THE GATE AND OPERATOR PRIOR TO DELIVERY, INSPECT ALL BOLTS FOR TIGHTNESS.

NOTE: Refer to pages 40 & 41 for final installation of your **ARM OPEN EDGE** during the attachment of gate.

1. Install Gate on Operator Arm.
2. Use (1) SS 3/4"-10 x 4 1/2" (STEEL GATE) or (1) SS 3/4"-10 x 5" (ALUMINUM GATE) Apply Never Seize to ALL SS bolt threads. Use (4) SS 1/2 x 1-1/2" Bolts for the lower mounting connection.
3. Insert the top bolt first and then the bottom four (4) bolts finger tight. Be certain gate is properly aligned before tightening. Tighten bottom bolts first, then tighten top bolt.
4. Linkage Arm is zip tied in the throat for shipping.
5. Locate Linkage Pivot Bolt kit (5/8" x 2-1/4") and follow the assembly diagram below. Tighten bolt to the gate lug hole. You may have to push down on the gate to insert Linkage Bolt.

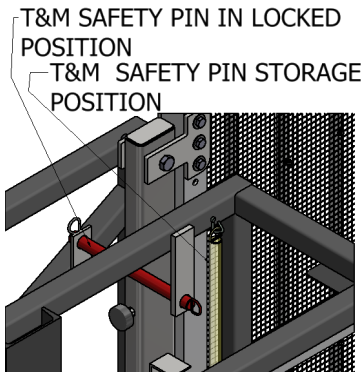

UPPER MOUNTING BOLT
(3/4-10 UNC X 4-1/2"-5"
DEPENDING ON GATE)

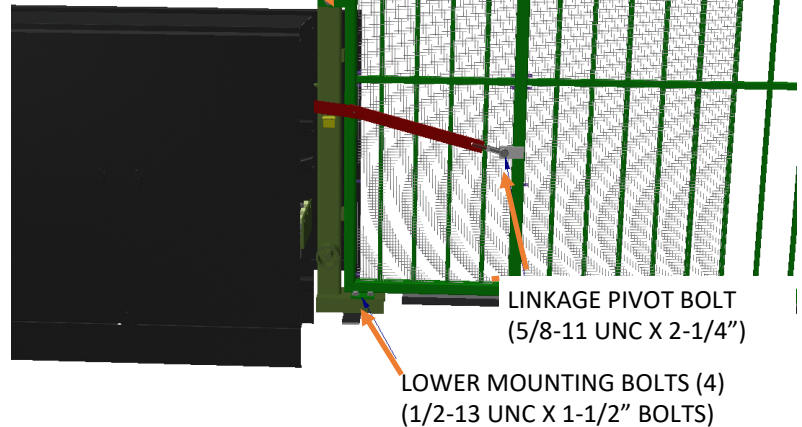

WARNING: NOT FOLLOWING ASSEMBLY INSTRUCTIONS MAY CAUSE SERIOUS INJURY OR DEATH AS WELL AS DAMAGE TO THE GATE OR OPERATOR.

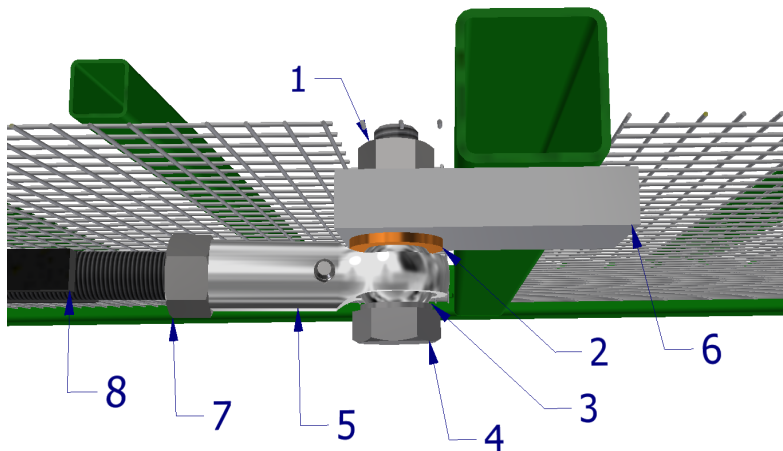

PARTS LIST	
#	DESCRIPTION
1	5/8-11 ZINC PLATED FULL HEX NUT
2	5/8" HEAVY WASHER
3	5/8" S.S. FLAT WASHER
4	5/8-11 x 2-1/4" LARGE HEX BOLT
5	5/8" DIA. 5/8-18 FEMALE ROD END
6	3/4" x 2" x 4" LUG
7	5/8-18 HEX NUT
8	LINKAGE ARM

LIFTING AND POSITIONING YOUR ASSEMBLED GATE AND OPERATOR

NOTE: It is recommended to attach Gate to Operator Arm before lifting (for better balance), but it is not mandatory. If using a Forklift to position Operator only, *lift from sides only!*

Do not try to lift gate and operator together from the side!

Use a lifting strap to lift Gate & Operator. The strap should be secured around Operator Arm and T/M Safety Pin or the top rail of the gate near the operator arm.



- 1) Place Gate & Operator Assembly on pad so the end of the Gate is centered over the Yoke pad or intended yoke position for the site (for yoke styles mounted to posts, buildings, etc.). Allow a minimum three (3") inches from edge of the operator pad to anchor bolt holes to prevent concrete damage.
- 2) Position and align Yoke and center under gate on the pad, to a post or wall.
- 3) Secure Operator with (1) 5/8" dia. Wedge Bolt in rear; check alignment on pad as well as gate panel alignment before installing (4) remaining anchor bolts.
- 4) Secure Yoke with four (4) 1/2" dia. Anchor bolts (provided). If installing a Ground Yoke, allow a minimum space of two (2") inches between bottom of Gate and Yoke.

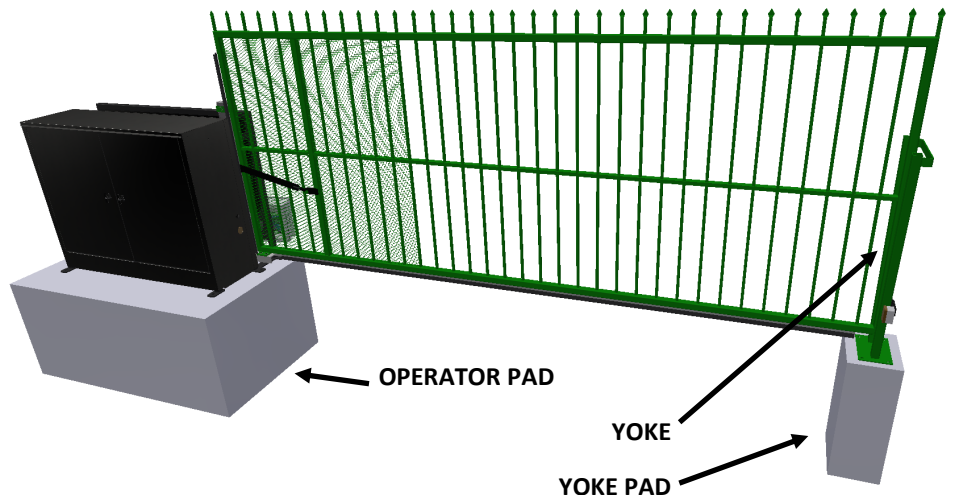

MANUAL OPERATION OF THE GATE

DO NOT ATTEMPT UNTIL THE OPERATOR HAS BEEN ANCHORED TO THE CONCRETE PAD!



WARNING: DO NOT REMOVE TRANSPORT/MAINTENANCE SAFETY PIN UNTIL THE GATE IS SECURELY ATTACHED TO THE OPERATOR ARM ACCORDING TO THE INSTRUCTIONS. SPRINGS AND OPERATOR ARM ARE UNDER LOAD AND REMOVING PIN COULD LEAD TO SERIOUS INJURY OR DEATH.

MANUAL OPERATION RELEASE PROCEDURE

WARNING! DO NOT ATTEMPT TO MANUALLY OPEN A MOVING GATE!

1. ROTATE THE **RED** HANDLE UNDER THE GEARMOTOR TO DISENGAGE THE DRIVE COUPLER.
2. REMOVE TRANSPORT/MAINTENANCE SAFETY PIN IF IT IS IN PLACE (behind Operator Arm) AND HANG ON THE HOOK PROVIDED.
3. IF GATE IS IN THE CLOSED POSITION, LIFT UP ON THE LINKAGE ARM WHILE HOLDING THE GATE. THE GATE IS UNDER SPRING TENSION AND WILL WANT TO TRAVEL OPEN.
4. MANUALLY PUSH THE GATE TO OPEN TO THE DESIRED POSITION AND MOVE THE **RED** LEVER BACK INTO PLACE. MOVE THE GATE UP OR DOWN SLIGHTLY TO LOCK THE COUPLER BACK IN PLACE.
5. IF THE GATE IS FULLY OPEN YOU CAN ALSO INSERT THE TRANSPORT/SAFETY PIN AND LOCK THE GATE OPEN.

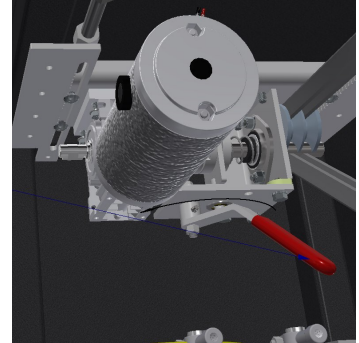

WARNING: DO NOT MAKE ANY PHYSICAL ADJUSTMENTS TO THE GATE POSITION UNTIL AFTER YOU HAVE TESTED IT. WITH THE T/M SAFETY PIN IN PLACE THE GATE MAY NOT BE FULLY CLOSED.

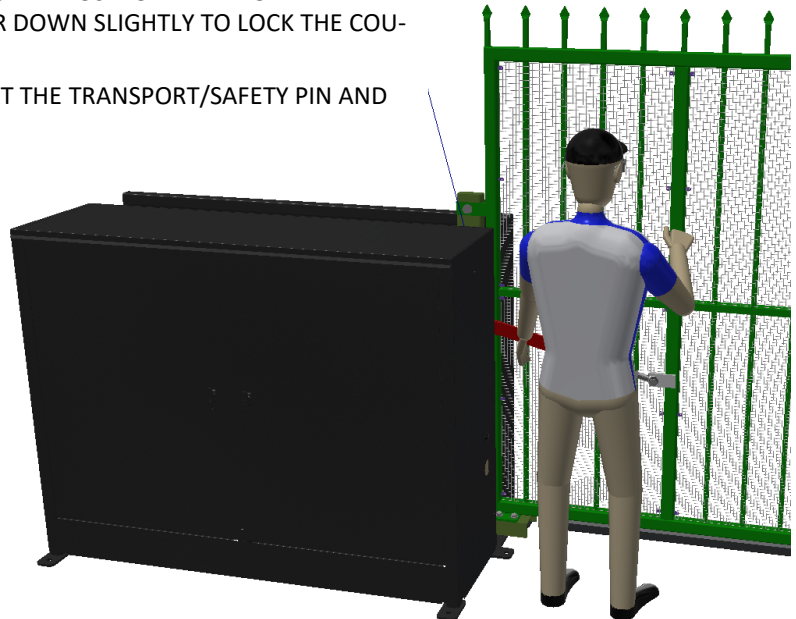

MANUALLY MOVE GATE TO DESIRED POSITION. RETURN RELEASE LEVER TO ENGAGE COUPLER AT NEW POSITION. GATE WILL SELF LOCK.

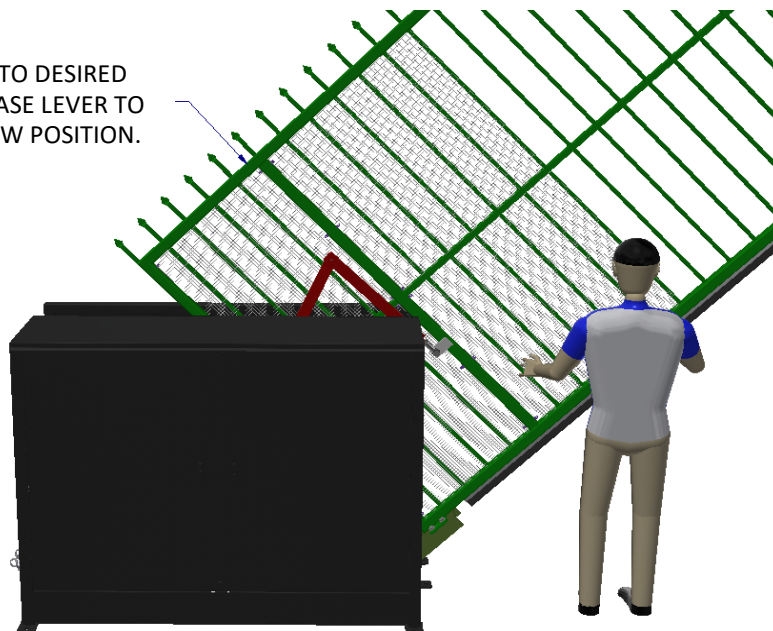

WINDBRACING

CABLE WIND BRACING

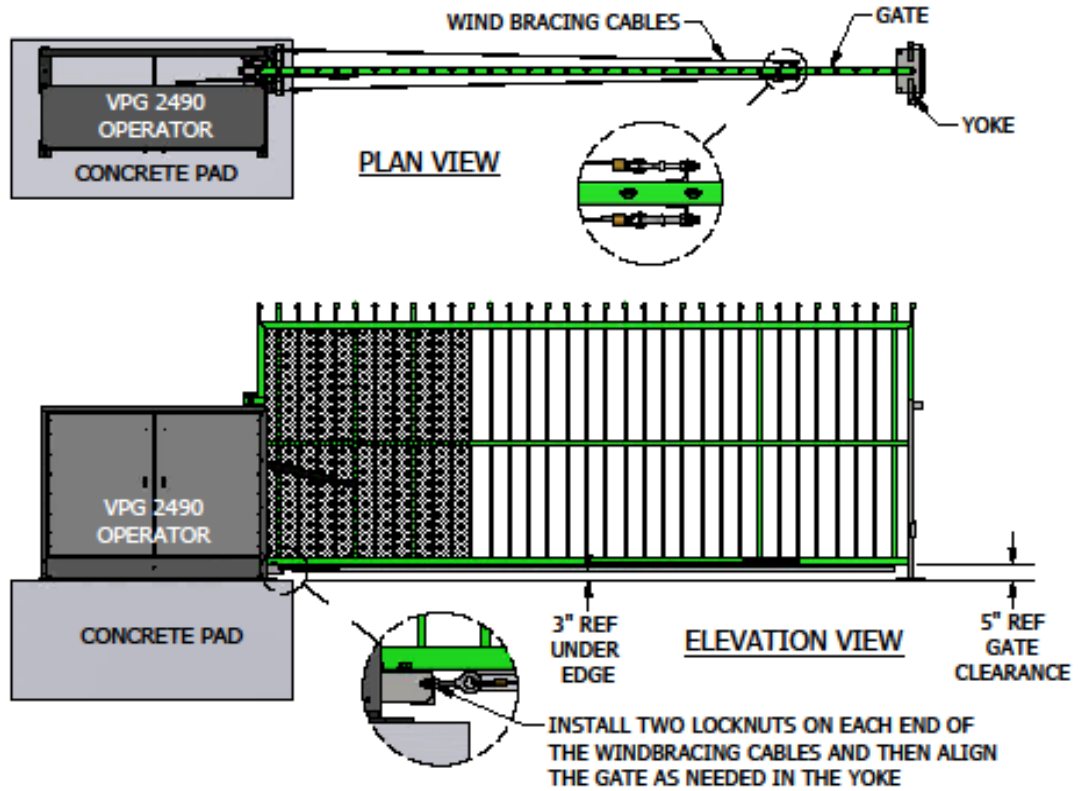

MASTED WIND BRACING

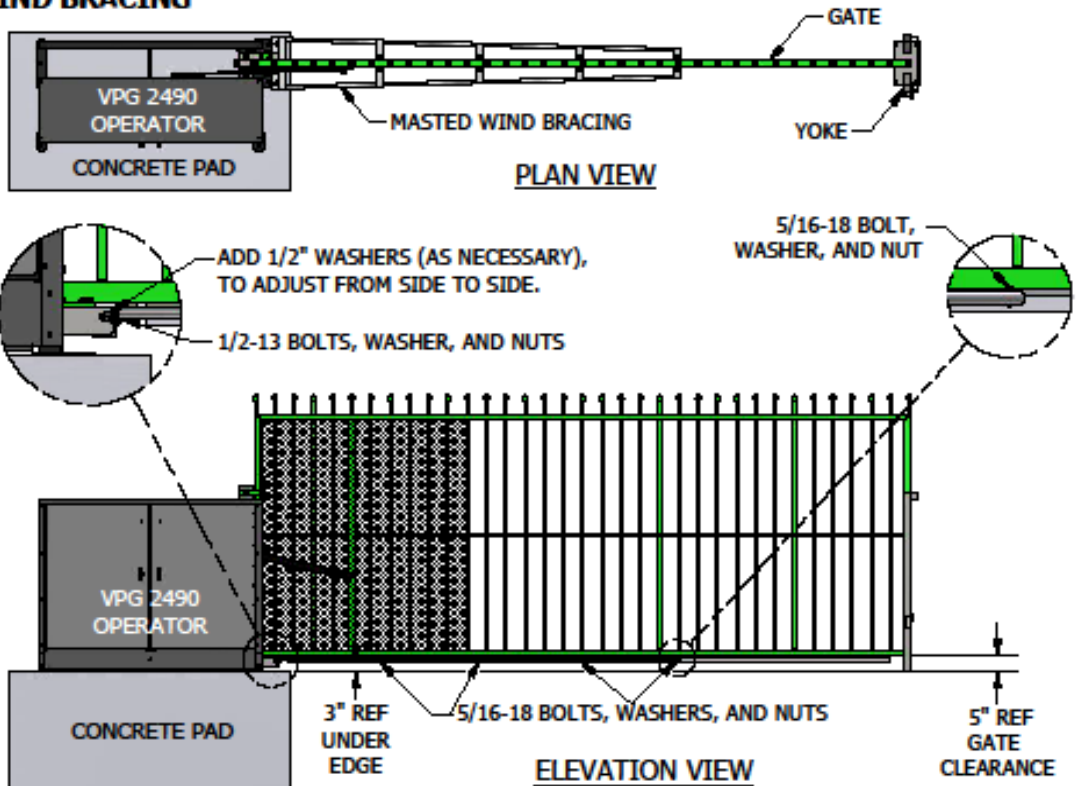

GATE GUARDS

1	GATES OVER 9' TALL WILL REQUIRE LOCAL FENCING (SEE ATACHED SHADED AREA)
2	AUTOGATE PROVIDES GATE GUARDS FOR 9' TALL AND UNDER THAT ARE CONSTRUCTED OF STANDARD MATERIAL. NON-STANDARD MATERIALS MAY NOT HAVE A PROVIDED GUARD. IF GUARD IS NOT PROVIDED: REVIEW YOUR ORDER AND DWG, CONTACT AUTOGATE.
3	FENCE OFF ALL AREAS PER F2200
4	INSTALL EXTERNAL ENTRAPMENT PROTECTION DEVICES TO MITIGATE THE POTENTIAL OF ENTRAPMENT.

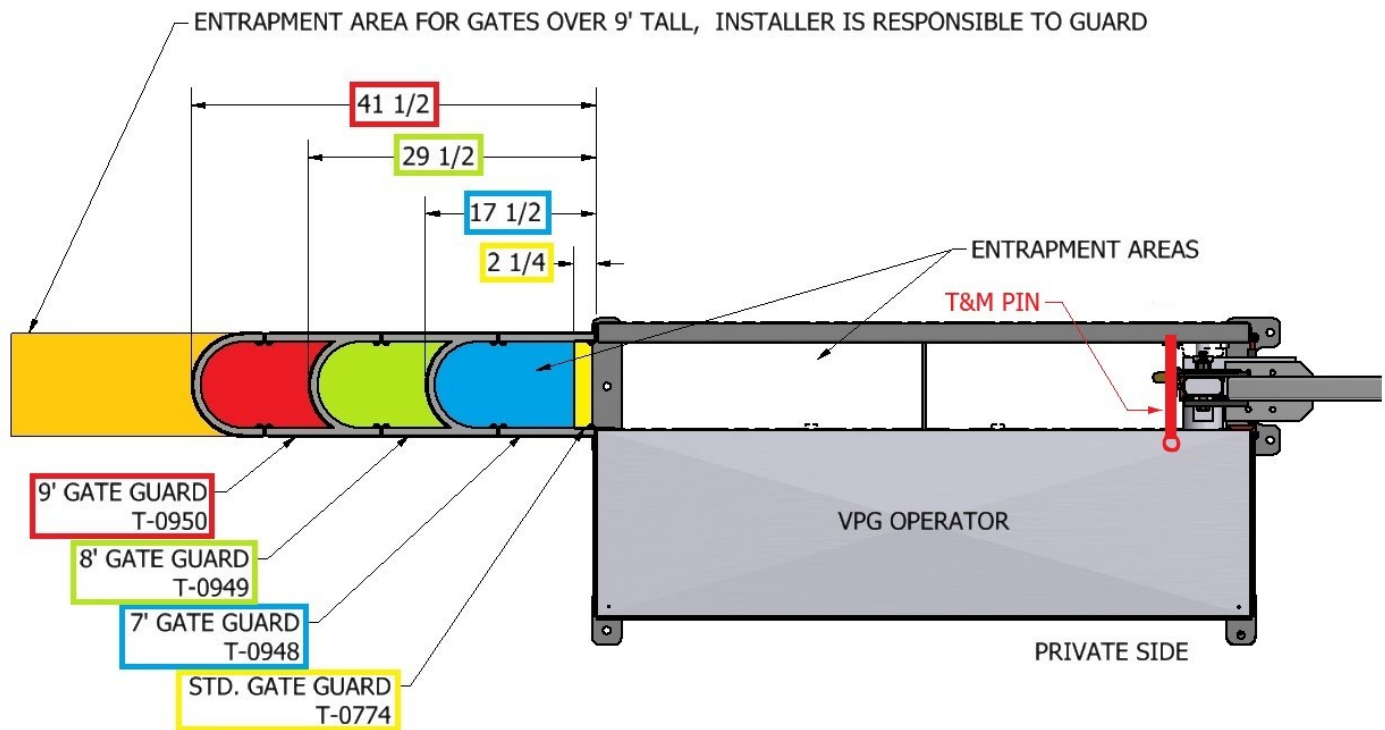

GATE GUARD INSTALLATION

GATE GUARD INSTALLATION INSTRUCTIONS

1: For standard sized gates (5' and 6')

- Align the Sheet Metal Gate Guard flush to the top of the operator and the inside of the throat as shown in **FIGURE 1**.
- Secure Gate Guard to the operator using Self- Drilling Tek Screws using the pre-existing holes in the operator skin.

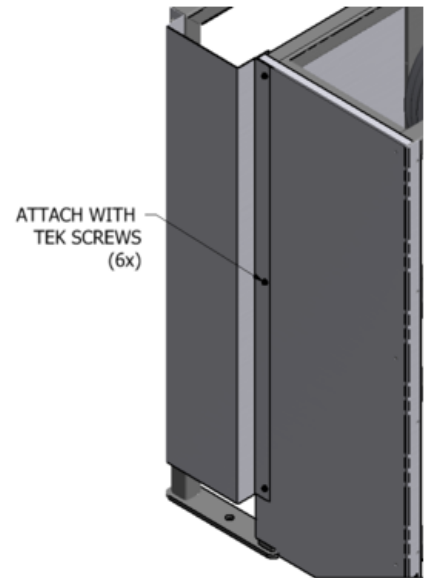

Figure 1

2: For gates 7' and taller

- Install (2) Mounting Clips to each of the Gate Guard side panels just inside the top and bottom tube using supplied self-drilling Tek screws as shown in **FIGURES 2 and 3**.
- Align Gate Guard End Cap and Side Panel flush as shown in **FIGURES 2 and 3**.
- Attach Gate Guard Side Panels to End Cap using Tek Screws.

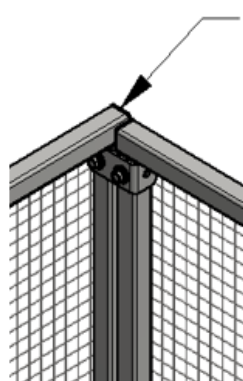

Figure 2

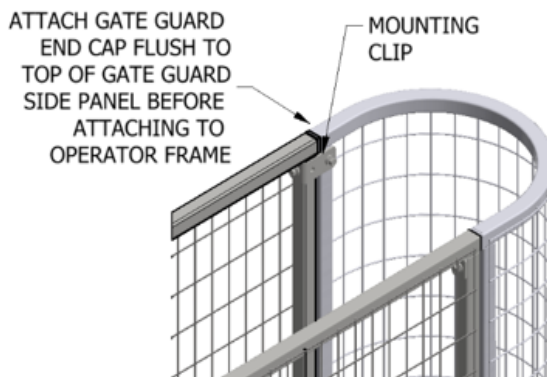

Figure 3

Note: Depending on Gate Guard style, the End Cap may be the flat or the hoop style.

GATE GUARD INSTALLATION (Con't.)

3: For 8' and 9' gates

- Attach (2) Gate Guard Stiffener pieces with supplied 1/4-20 Bolt and Nylon Lock-Nut through the center hole.

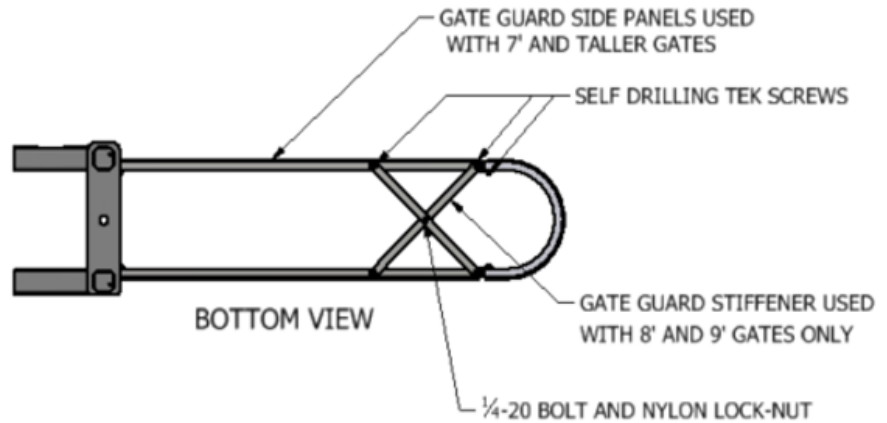

Figure 4

- Attach Gate Guard Stiffener to the bottom of the Gate Guard Side Panels with (4) Tek screws as shown in **FIGURE 4**.

4: For gates 7' and Taller

- Install (2) Mounting Clips to each of the (2) Gate Guard Side Panels just inside of the top and bottom tube using Tek Screws (1 per Clip) as shown in **FIGURE 5**.

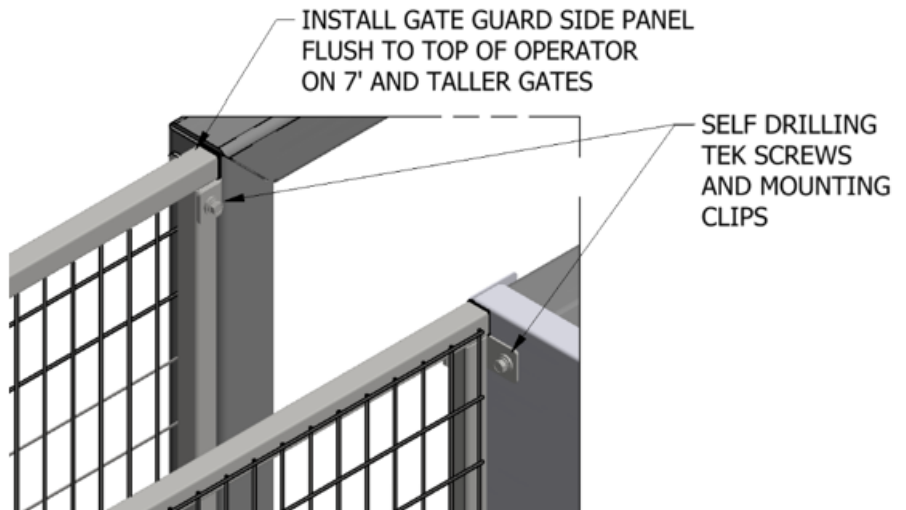

Figure 5

- Align Gate Guard Side Panel flush to the top of the Operator as shown in **FIGURE 5**.
- Secure Gate Guard Side Panels to the Operator using (4) Tek Screws through the holes in the Operator Skin as shown in **FIGURE 5**.

SECTION 5—OPERATOR ELECTRICAL

The AutoGate Genesis control board is DC powered as is the motor/gate controller with built in full battery back-up. Primary power is supplied by an AC rectified output power supply (see below). Input AC is supplied through a dedicated 20 Amp breaker. Voltage is selectable, 90~132 VAC / 180~264 VAC via slide switch. This protects the Genesis controller from random or storm induced power surges on while AC power. The Earth Ground connection on the board is to aid in surge protection and random voltage issues.

NOTE: There is NO AC power inside the Control Board Enclosure!

A/C POWER CONNECTION



WARNING: ALL 120VAC OR 240VAC ELECTRICAL CONNECTIONS FROM SERVICE PANEL TO THE GATE OPERATOR MUST BE MADE BY A LICENSED ELECTRICIAN!

- Run AC power lines through conduit to junction box (see below) located inside the operator. (see typical conduit locations drawings page 15. Contact AutoGate for Optional routing).
- All AC power and control wiring MUST be run in separate conduits.
- Before doing any wiring inside the operator ensure that the main power source has been disabled at the main circuit breaker. If this is a **SOLAR** application, ensure the power input is disconnected.
- The Power Supply will be wired at the factory, you only need to wire the AC into the supplied junction box.

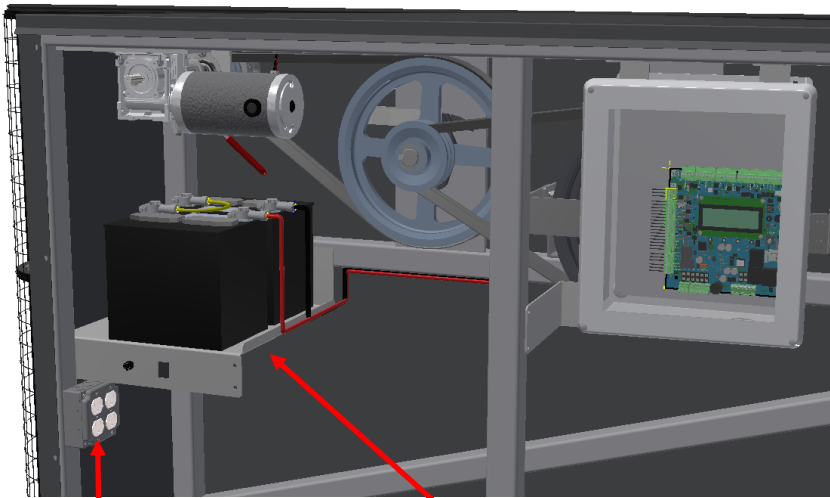

AC Junction Box

Rectified Power Supply
(Mounted under the battery shelf)

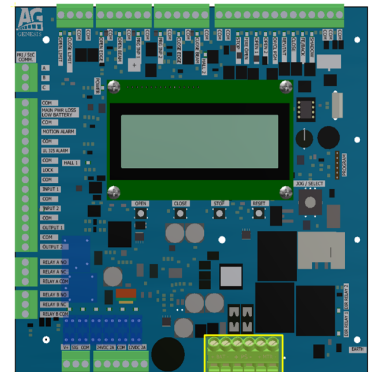
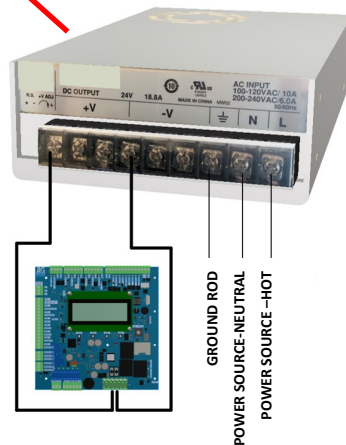

P11

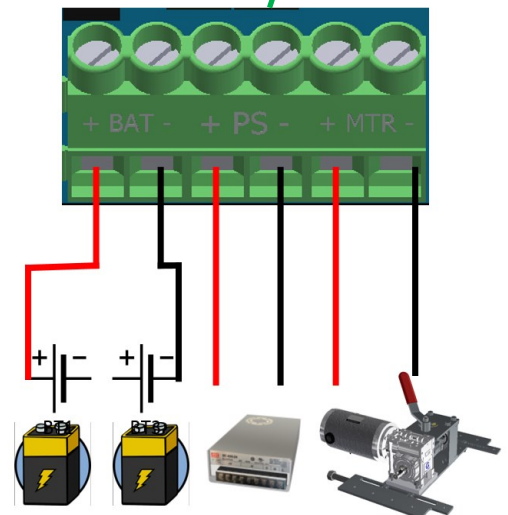

EARTH GROUND AND LIGHTNING PROTECTION

Install an approved 8' earth ground rod 6" to 3' off the rear side of operator pad*. The Ground wire connection is located inside the door. Recommended wire is #8 gauge or larger. **NEVER splice the ground wire!**

Improper grounding will make the operator more susceptible to lightning or surge damage and can affect GENESIS Board or accessories.

To Operator

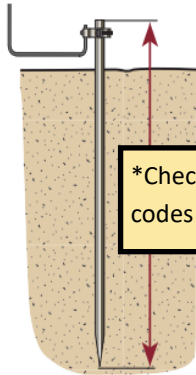

*Check national and local codes for proper depth.

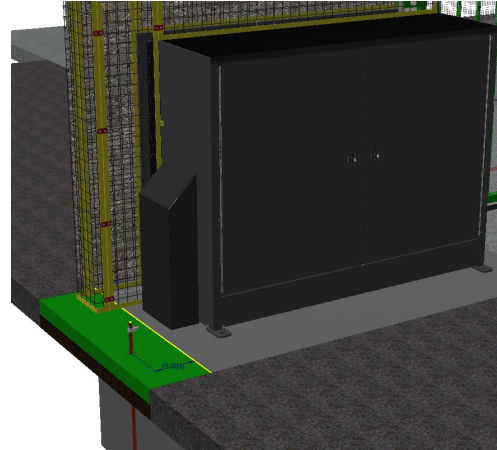

BATTERY WIRING AND INSTALLATION

The Genesis controller has a built-in battery charging system that has multiple formats. The charging sequence can handle full size flooded batteries as well as sealed lead acid or AGM batteries. The Genesis primary input voltage can also be connected directly to solar panel(s) for non-AC operation. The built-in charger when programmed for solar will allow the system to run off the batteries and will still charge them during the daylight hours.

Install Two (2) 12 VDC Batteries (**Required, not provided**) on the battery shelf. AutoGate recommends Group 24, 80-100 Amp Hour Deep Cycle Marine Starting batteries for extended battery back up. At a minimum use (2)- 7AH batteries for battery back up.

BATTERIES MUST REST IN A LEVEL POSITION ON THE BATTERY TRAY TO AVOID ACID LEAKING FROM BATTERIES.

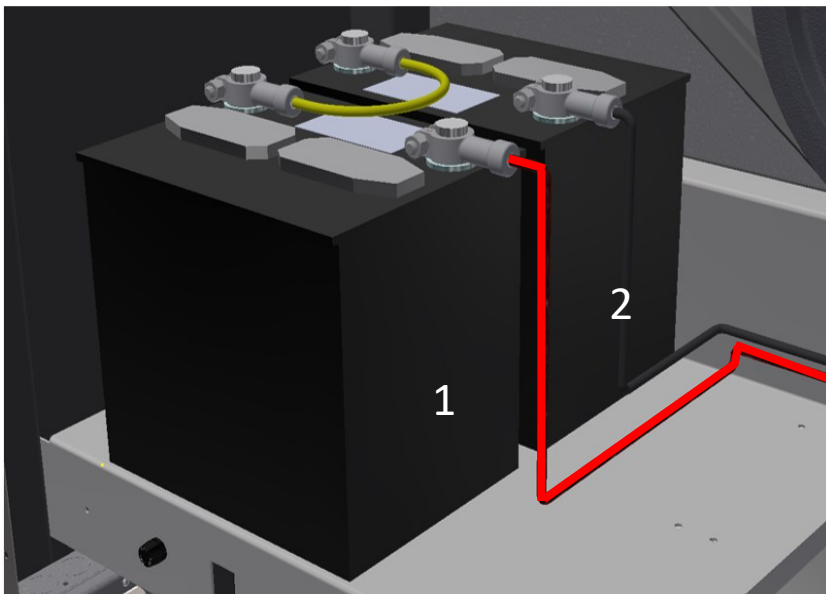

Typical 24V series connection

- 1) Jumper wire from battery 1 NEGATIVE is connected to battery 2 POSITIVE.
- 2) Wire from battery 1 POSITIVE to POSITIVE terminal on control board
- 3) Wire from battery 2 NEGATIVE to NEGATIVE terminal on control board.

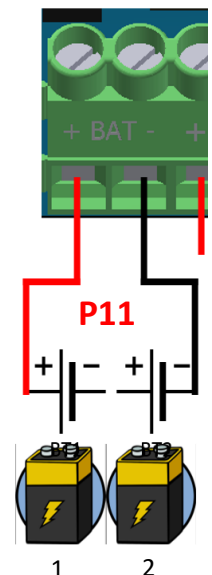

Batteries will charge when AC power or Solar Panels are present and power gate automatically without any changes in wiring. **Note:** Solar applications will require a program selection in the board menu (see page 33.)

SECTION 6—GENESIS CONTROL BOARD

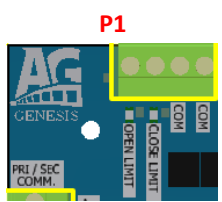
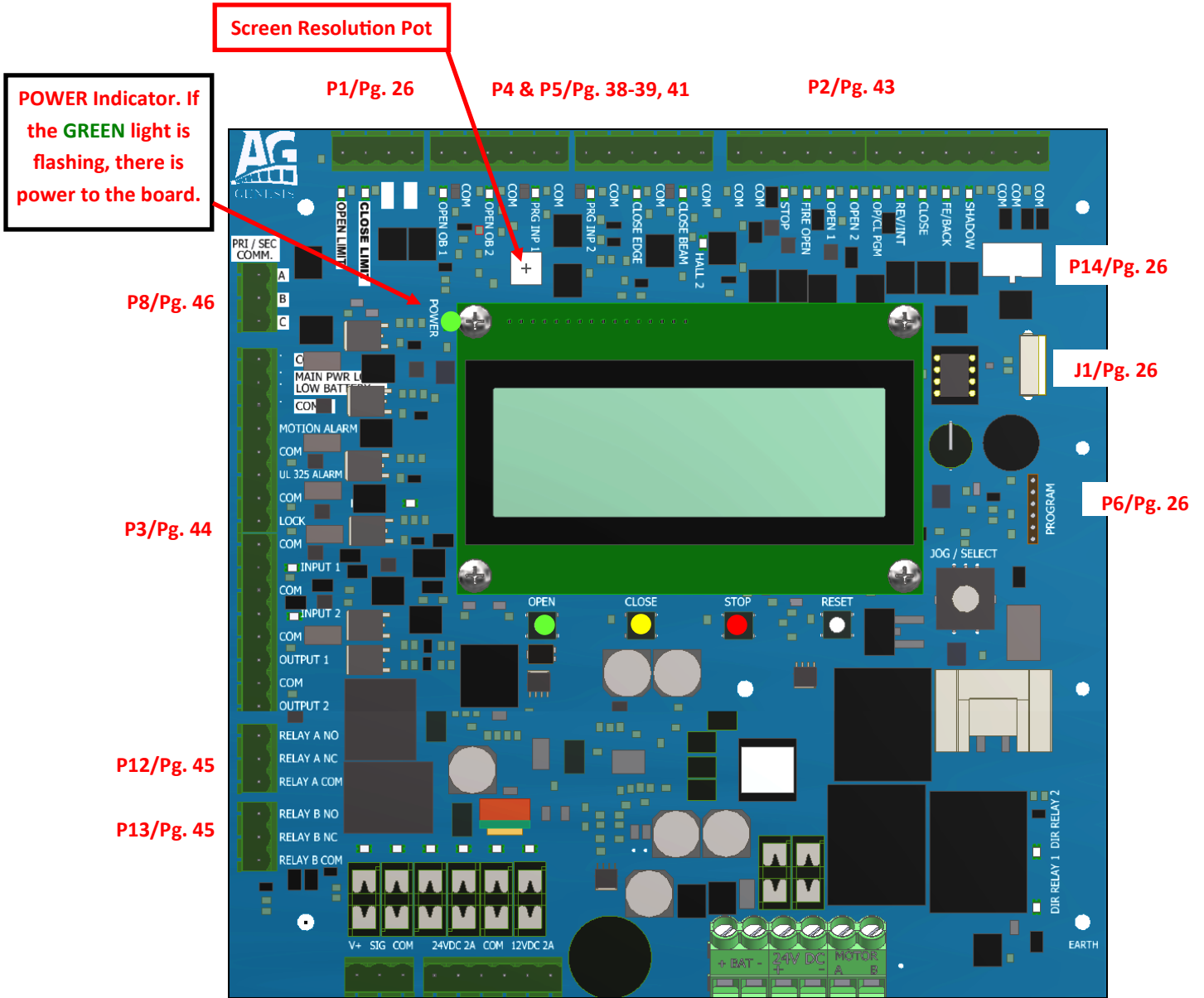

Note: **P1** is NOT USED on the VPG2490 model. The VPG2490 uses a **Limit Position Sensor (LPS)**. **P1** would only be used if you were to install the GENESIS board in an older operator with limit switches.

P14— Loop Rack Accessory Wiring harness port: Used with our LR-3 Loop Rack board

J1—USB For data connection

P6—Program Plug: Used to update board software

GENESIS BOARD OPERATION BUTTONS

- **GREEN:** OPEN (Will also act as a constant pressure and override defaults to OPEN the gate)
- **YELLOW:** CLOSE (Will also act as a constant pressure and override defaults to CLOSE the gate)
- **RED:** STOP (Stops the gate in either direction)
- **WHITE:** RESET (Resets the board in the event of a program change or fault)

VPG-2490 WIRING DIAGRAM 120VAC

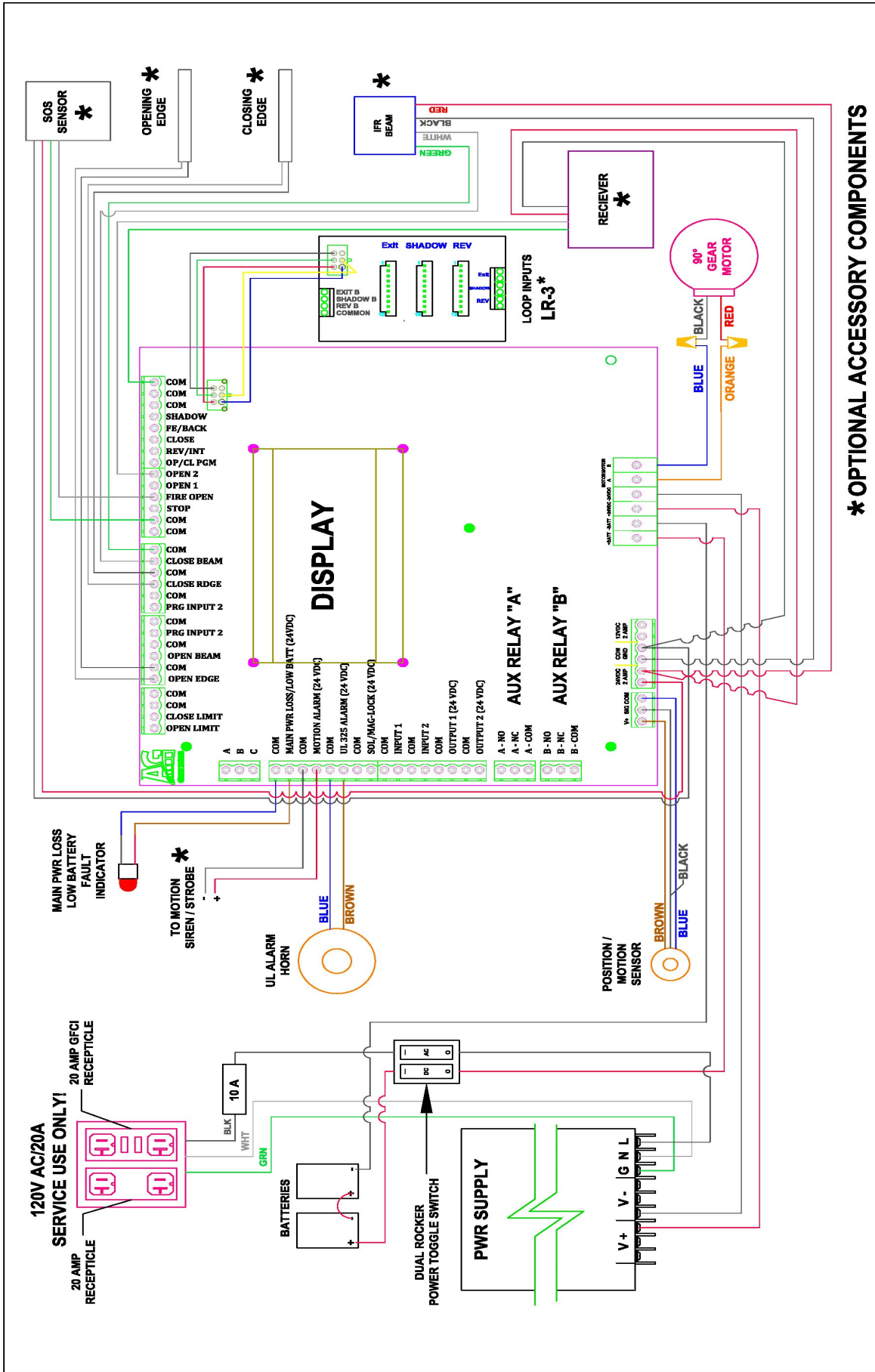

* OPTIONAL ACCESSORY COMPONENTS

AG		AutoGate Gate Entry Systems Bethel Heights, Ohio FAX (419) 688-3514	
Date Dwn:	8/18/18	Dwn. By:	EGS
		Chd. By:	
Dwg.: AG# Genesis Board Wiring Schematic.dwg			
Title: VPG-2490 Wiring Diagram			
E:\GENESIS BOARD\PRODUCTION\GENESIS BOARD WIRING SCHEMATIC.DWG			
NOTICE		DO NOT SCALE	
THE INFORMATION CONTAINED ON THIS DOCUMENT IS CONFIDENTIAL AND NOT TO BE DISCLOSED OR COPIED WITHOUT THE WRITTEN PERMISSION OF THIS INFORMATION IS STRICTLY PROHIBITED		UNLESS OTHERWISE SPECIFIED DIMENSIONS ARE IN INCHES ANGLES ± 1° XX ± 1/32, XX ± .01, XXX ± .005	
Rev.:	Description:	Date:	Chd. By:

VPG-2490 WIRING DIAGRAM 240VAC

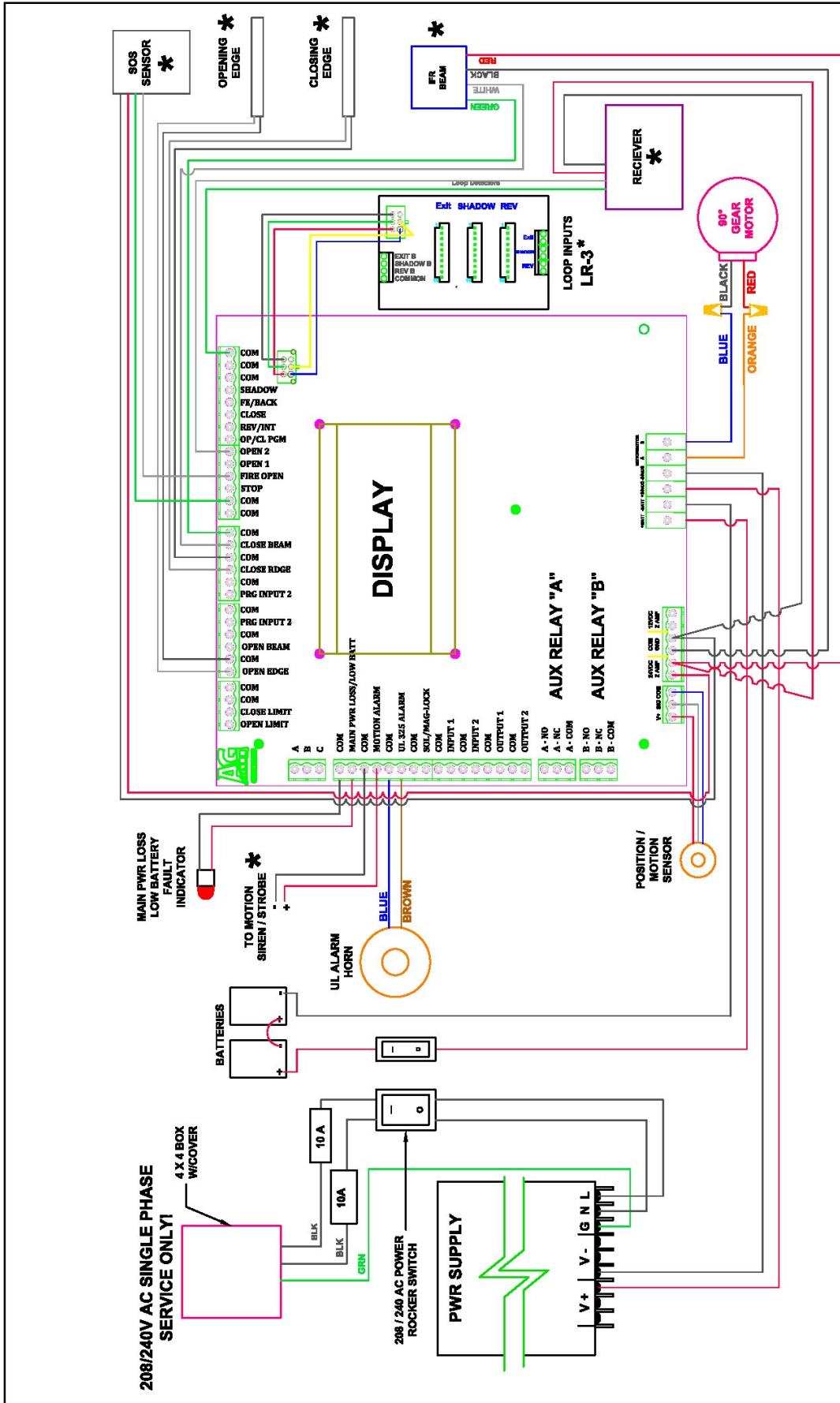

*** OPTIONAL ACCESSORY COMPONENTS**

AutoGate
Gate Entry Systems
Bedin Heights, Ohio
PAK (419) 488-3614

AG

Date Drawn:	01/03/19	Drawn By:	EGS
Checked By:			
Dwg./AG#: Genesis Board Wiring Schematic - 240 Volt Input			
Title: VPG-2490 Wiring Diagram-208/240 Volt			

NOTICE: THE INFORMATION CONTAINED ON THIS DOCUMENT IS CONFIDENTIAL. ANY DISSEMINATION, UNAPPROVED BY THE ISSUING OFFICE OF THIS INFORMATION IS STRICTLY PROHIBITED. UNLESS OTHERWISE SPECIFIED DIMENSIONS ARE IN INCHES ANGLES ± 1° XX ± .132, .XX ± .01, .XXX ± .005

DO NOT SCALE			
Rev.:	Description:	Date:	
Drn. By:	Chd. By:		

GENESIS CONTROL BOARD

OVERVIEW: The GENESIS board has a 4 line 20 characters per line LCD backlit screen. At power up, the display will show the AutoGate and GENESIS branding, along with the program version number and the current time. After 5 or 6 seconds, this will then shift to the HOME screen, or base operational data shown below under MAIN Screen.



```
AutoGate Ver. A#.#
GENESIS 01:22am
```

TITLE Screen

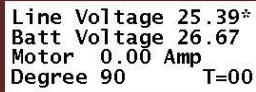

```
Line Voltage 25.39*
Batt Voltage 26.67
Motor 0.00 Amp
Degree 90 T=00
```

MAIN Screen



```
>Auto Close: Off
Auto Delay: 03
```

Example 1



```
Auto Close: Off<
Auto Delay: 03
```

Example 2

JOG/SELECT Control Knob: The screens are accessed and modified by a JOG/SELECT control knob. Turning the Jog/Select dial will scroll through the sub-menu selections. When a sub-menu is showing, a quick momentary press of the Jog/Select knob will display the first screen in that sub-menu. Turning the Jog/Select knob will move the cursor (>) through the adjustable parameters.



JOG/SELECT Knob

SCROLLING: Rotating the Jog/Select knob clockwise will scroll through the adjustments on that screen. If there is another screen in that sub-section, continue to scroll after the last character, the screen will automatically change to the next screen. When at the last screen of a sub-section, a long push, (approx. 1 second), of the Jog/Select knob will return to the sub-section main screen. Sub-sections can be scrolled in either direction by turning the Jog/Select knob clockwise or counter-clockwise.

JOG/SELECT ACTIONS: Two different actions can occur on the screens:

- 1) If the cursor is pointed to a descriptive phrase (Example #1), then a momentary push of the Jog/Select knob will move the cursor to the adjustable parameter. Then turning the Jog/Select knob will change the value.
- 2) When the cursor is pointed to left side of a value or parameter to be changed, (example #2), use quick momentary push of the Jog/Select knob to move the cursor. The cursor will move to the right side of the value (<). Turning the Jog/Select knob will change the value. When done, again, a quick momentary push of the Jog/Select knob moves the cursor back to the left.

Note: Gate will not be operational while in programming mode. When in programming mode there will be a series of flashing lights at all times above the LCD screen.

Note: Screens in ORANGE are **WARNING** screens that will appear when there is an issue.

Note: There is a Screen Contrast Pot is located above the screen on the top left.

SCREEN MENUS

MAIN SCREEN



```
Line Voltage 25.39*
Chrg.Voltage 26.67
Motor 0.00 Amps
Cycles 0 T=00
```

Line voltage: From the Power supply. (Normal voltage will be 26 to 27, Preset to 26.5Vdc)

Charge/Battery voltage: When AC present: Charging Voltage to batteries, When on DC only: Actual battery voltage. (Normal voltage is 26.4 to 26.8) **Note: * Indicates CURRENT POWER source**

Motor: Displays actual motor amperage during cycling

Cycles/Position: A cycle count is considered a complete OPEN & CLOSE. Hold the Jog/Select button down and the Cycles will change and show the gate position "0" being CLOSED and "90" being full OPEN.

T=00: Operation count in seconds for both open and close cycles and also counts down the "Timer to Close" (CLOSE TIME) time.

CALENDAR/TIME



```
Calendar/Time
```

Set the time, date and day of the week. This is an important feature. It will affect the data in all FAULT and OPERATION logs as well as any TIME functions to hold the gate open on any given day(s).

GENESIS CONTROL BOARD

CALENDAR/TIME (cont.)

```
>01:14:58 am  
03/21/19 Th
```

Set the time, date and day of the week.

TIMER SETTINGS

```
Timer Settings
```

TIMER SETTINGS: 4 Sub Menus to set OPEN & CLOSE times, MOTION ALARM times and 7-DAY TIMERS

```
Auto Close: off  
Auto Delay: 03
```

AUTO CLOSE TIME: Default is **ON** from 1 to 120 seconds, **OFF** requires a **CLOSE** command.

CLOSE TIME DELAY: Timer to close after all inputs are clear. Settable from 1 to 120 seconds.

(Note: If using the "Auto Close" in a **PRIMARY/SECONDARY** gate system, *only set the PRIMARY "Auto Close" to on, leave the Secondary off*).

OPEN/CLOSE TIME (*This option is only active when LIMITSWITCHES are used*): Full Speed Run Time, Set this when the slow down is to start. Slows down after time value expires.

```
>Motion Alarm: On  
Pre-Op Alarm: 0  
Pre-CI Alarm: 0
```

MOTION ALARM: Turns ON and OFF an alarm or Strobe Light.

PRE-OPEN ALARM: Turns on the alarm from 1 to 5 seconds *before* the gate opens.

PRE-CLOSE ALARM: Turns on the alarm from 1 to 5 seconds *before* the gate closes.

*Note: This time value must be equal to or shorter than the **AUTO CLOSE TIME** value. (*Refer to page 44 for Board Wiring Terminals*)

```
>Automatic Schedule:  
Off
```

AUTOMATIC SCHEDULE: Sets the gate to lock **OPEN** and **CLOSE** daily, 7 Days a week, Monday thru Friday or Saturday & Sunday only

```
Automatic Schedule:  
>7 days a week
```

```
Automatic Schedule:  
>Mon-Fri only
```

```
Automatic Schedule:  
>Sat & Sun only
```

```
Automatic Schedule:  
>Custom-Daily
```

Set the time, date and day of the week individually. Two complete options for each day: **SUNDAY** to **SATURDAY** and **SUNDAY 2** to **SATURDAY 2**.

```
Monday  
>On  
Open: 08:00 am  
Close: 06:00 pm
```

Each day has the ability to set a **HOLD OPEN** and **CLOSE** time.

```
Thursday 2  
OFF<  
Open: 06:00 am  
Close: 05:00 pm
```

(Same as above) Each day has the ability to set a *second* **HOLD OPEN** and **CLOSE** time.

GENESIS CONTROL BOARD

OPERATOR CONTROL

Operator Control

OPTIONS: GATE SPEED, LIMIT SWITCHES, HALL (A & B), OPEN/CLOSE, POSITION SETTINGS

>Gate Orientation:
Right

GATE ORIENTATION: Set for LEFT or RIGHT hand gate. *The hand is always determined from the INSIDE or PRIVATE side of the gate system.* If the operator is located on the right-RIGHTHAND, left-LEFTHAND.

>Dual Gate Mode:
>Off
Status Disconnected

DUAL GATE MODE: Turn "ON" when you have (2) gates opening at the same time.
Options: OFF, PRIMARY or SECONDARY. If "ON", then each gate needs to be set accordingly
STATUS: Disconnected or Connected

- If using the "Auto Close", only set the PRIMARY "Auto Close" to on, leave the Secondary off
- Make sure both gates are powered up, otherwise you receive a "communication" error message (see yellow message below)

Gate set in DUAL
Mode: Primary or
Secondary not
detected

In a PRIMARY/SECONDARY or DUAL gate mode system, if you lose communication between the two operators you will get this message.

Note: *Gates will not operate in DUAL gate mode unless BOTH are powered up and connected.*

>Gate Opening Speed:
100%
Gate Closing Speed:
100%

GATE SPEED: Default 100%, any percentage less than 100% down to 75% will slow the gate opening and closing down accordingly. Downward speed to fast will cause a **FAULT: SPEED OVER-RUN** (see below).

>Limit Switches:
Not Used

LIMIT SWITCHES: *(REQUIRES SECURITY CODE TO ACCESS)* Default is "NOT USED". Model VPG 2490 systems are equipped with a **LIMIT POSITION SENSOR (LPS)**. *If no sensor is present, then a fault code is generated and the gate will not move.* Choices are: **NORMALLY OPEN, NORMALLY CLOSED, HALL & HALL B.** Normally open & close will choose the type of wired Limit Switch to be used.
HALL A & HALL B: *Only used on direct replacements on certain barrier gate operators.*

>Open Decel: 10
Close Decel: 10

DECEL SPEED: Sets the time value on setting the gate speed from full speed to slow speed. The scale is 7 to 20, with 7 being the fastest and 20 being the slowest.

WARNING! No Limit
Position Sensor
detected! Gate will
not operate!

WARNING! Downward
Speed too fast.

>Const Press Mode:
Off
Stop Input Mode:
Normally Open

CONSTANT PRESSURE (CP) MODE (CLASS IV): In the CP mode, the OPEN 1, OPEN 2 & CLOSE inputs can be wired to a push button station for gate control. In a CP mode, these inputs will override the Entrapment STOP/ALARM condition. Status is ON or OFF only. Default is OFF.
STOP INPUT MODE: Either Normally OPEN or Normally CLOSED (Factory default is always OPEN!) Only switch to CLOSED if you are using a 3-button station that requires it to be normally CLOSED or a Mushroom E-Stop

WARNING! Use caution when using these inputs. Always have direct line of site to the gate at all times to avoid pedestrian injuries or equipment/vehicle damage.

GENESIS CONTROL BOARD

MONITORED INPUT SETTINGS

Monitored Input Options

OPTIONS: OPEN OBSTRUCTION, CLOSE OBSTRUCTION, PROGRAMMED MONITORED INPUTS:
Choices are: 10K (10,000 Ohms Resistance) or 2-Wire.

(The GENESIS board supports a maximum number of (2) OPEN, (2) CLOSED & (2) programmable inputs. Contact AutoGate if additional inputs are required).

WARNING Monitored Input missing See LED indicators For Monitored

Board is programmed for a Monitored Input. If it is missing, gate will not operate until the **monitored** input is installed or restored.

"Monitored" device is enabled and the req'd feedback (10K-Pulse) is missing

Board is programmed for a Monitored Input. If it is enabled and the required feedback is missing you will get these FAULTS: CLOSE BEAM MISSING, OPEN BEAM MISSING, CLOSE EDGE MISSING, OPEN EDGE MISSING. PGM INPUT 1 MISSING, PGM. INPUT 2 MISSING. You will need to re-establish the monitored device.

WARNING! Obstruction An intended Input or manual reset req'd. to restore use.

If your gate has a monitored UL Event and either "locks" open or goes "closed", this warning screen will appear as well as the FAULT light will flash. Any intended INPUT will reset the gate to normal operation. Providing the obstruction is no longer present. You can also "manually" reset the board.

Open Obstruction:
>OB1:Edge 10K
OB2:Beam 10K

OPEN OBSTRUCTION: Either an EDGE or BEAM will work on either OB1 or OB2. You have (3) choices: OFF, 10K or 2-WIRE. You must have a minimum of (1) programmed at all times for UL325 Rev. 6 and up.

WARNING! Obstruction An intended Input or manual reset req'd. to restore use.

If your gate had an OPEN OBSTRUCTION event, the gate will stop and reverse to full close until the obstruction is cleared and an INTENDED INPUT (Access Control Input, Loop Reset, etc., but NOT the CLOSE TIMER) or a MANUAL INPUT on the control board resets your gate back to normal operation.

Close Obstruction:
>Edge: Off
Beam: 10K

CLOSE OBSTRUCTION: You have (3) choices: OFF, 10K or 2-WIRE. You must have a minimum of (1) installed and programmed at all times per UL325 latest edition. CLOSE OBSTRUCTION DEVICES are approved Beams and Edges only! **NEVER HOOK A BEAM TO THE EDGE INPUT!**

WARNING! DOUBLE DEFAULT! Push RED STOP or RESET button to restore use.

If your gate had a **DOUBLE CLOSED EDGE OBSTRUCTION** event, the gate will shut down in the OPEN position until the obstruction is cleared and an INTENDED INPUT (Access Control Input, Loop Reset, etc., but NOT the CLOSE TIMER) or a MANUAL INPUT on the control board resets your gate back to normal operation.

Prog Mon Input 1:
>Open Edge 10K
Prog Mon Input 2:
Close Beam 10K

PROGRAM MONITORED INPUTS: Additional INPUTS for additional monitored devices. Choices are: OFF, 10K: OPEN EDGE, OPEN BEAM, CLOSE EDGE & CLOSE BEAM
2-WIRE: OPEN EDGE, OPEN BEAM, CLOSE EDGE & CLOSE BEAM.

WARNING! Obstruction An intended Input or manual reset req'd. to restore use.

If your gate had an OBSTRUCTION event, depending on the monitored device, the gate will shut down either in the OPEN or CLOSED position until the obstruction is cleared and an INTENDED INPUT (Access Control Input, Loop Reset, other) or a MANUAL INPUT on the control board will reset your gate back to normal operation.

WARNING Double Fault Red Stop input or manual reset req'd to restore use.

If your gate had a DOUBLE FAULT, it will be shut down. To restore normal activity, check for obstructions and if clear, hit the RED STOP button, do a manual reset or power the system down and back on again.

GENESIS CONTROL BOARD

INPUT OPTIONS

Input Options

OPTIONS: INPUT 1 & 2

All of the INPUTS will require a momentary pulse from a remote source such as a Pushbutton, Toggle Switch, etc.

>Input 1 Mode:
Off
Input 2 Mode:
Off

INPUT (1 & 2) MODES:

OFF

OPEN-Open command

CLOSE-Close command

Single Button-Open-Stop-Close-Stop

Reverse-Reverse command

Fire-Holds the gate Open (*will cause a FLASHING ALERT warning screen*)

Shadow-Shadow Loop input

Auto Open: Default is OFF-Skips the next days 7-Day Timer cycle commands

Hold Open-Opens gate: Holds open until Input removed (*will cause a FLASHING ALERT warning screen*)

Emergency Secure-Gate will NOT open (*will cause a FLASHING ALERT warning screen*)

Emergency Close-(*Custom programmed, contact AutoGate for this option, requires security access code*)

Aux 1 Pulse-Pulses Auxiliary 1 contacts

Aux 1 Hold-Holds Auxiliary 1 contacts until triggered

Aux 2 Pulse-Same as Pulse 1

Aux 2 Hold-Same as Hold 1

WARNING! FIRE SWITCH IS ENABLED. Hold Stop and press Jog/select to clear

WARNING! HOLD OPEN IS ENABLED, gate will not close until released

WARNING! EMERGENCY SECURE is enabled. Gate will not OPEN until released

>Aux Input 1 Delay
5 Seconds
Aux Input 2 Delay
0 Seconds

AUXILLARY INPUT 1 & 2 DELAY: Option to delay the INPUT from firing and opening the gate. Settable from 1 to 20 seconds

>Open/Close Pgm In:
Off

Open/Close Program: Programs the OP/CL PRM Input under P2 on the board to either: OFF, OPEN only or OPEN and CLOSE.

AUXILIARY OUTPUT OPTIONS

Aux Output Options

OPTIONS: AUXILIARY RELAYS (A & B), OUPUT (1 & 2), PROGRAMMABLE LOCK

AUX RELAYS will switch contact between NORMALLY OPEN and NORMAMLLY CLOSED from a common input.

AUX OUTPUTS physically switch 24VDC ON or OFF

>Output 1 Quick Set:
Always Flashing
Output 2 Quick Set:
Flashing Closed

OUTPUT QUICK SET OUTPUT 1 & 2: 4 Quick Set options for flashing lights:

Choices are:

No Preset: Off

Always Flashing: Light Flash 24/7

Closed & Motion 1: Always flashes except on solid on full open

Closed and Motion 2: Always flashes except off on full open

Flashing Closed: Lights flash when the gate is closed only

GENESIS CONTROL BOARD

AUXILIARY OUTPUT OPTIONS (cont.)

>Relay A Mode:
Off
Relay B Mode:

AUXILIARY RELAYS (A & B): Either relay can be set for a variety of functions:

OFF
Pulse on Open Limit
Pulse on Close Limit
Hold on Open Limit
Hold on Close Limit
Pulse on Motor Open
Pulse on Motor Close
Hold on Motor Open
Hold on Motor Close

Note: When installing an accessory item (traffic light, siren, etc), you need to run the COMMON down to our **POWER TERMINAL** (common) and then take a wire from the **24vdc** up to the RELAY A or B COMMON. This will provide power to your unit.

>Output 1 Mode:
Hold on Aux 2
Output 2 Mode:
Off

OUTPUT (1 & 2): Either relay can be set for a variety of functions and provides 24vdc power

OFF
Pulse on Open Limit
Pulse on Close Limit
Hold on Open Limit
Hold on Close Limit
Pulse on Motor Open
Pulse on Motor Close
Hold on Motor Open
Hold on Motor Close
Hold on UL Alarm
Hold on Motor Run
Hold Always
Pulse Always
Hold Not Open Limit
Pulse Not Open Limit
Hold Not Close Limit
Pulse Not Close Limit
Hold Not Opening
Pulse Not Opening
Hold Not Closing
Pulse Not Closing
Pulse On Motor Run

Note: For all accessories (lights, alarms, etc.), check on www.autogate.com for technical data or refer to the manufacturer's technical data and installation sheets.

>Programmable Lock:
Magnetic
Aux Output states:
Out1 N-O, Out2 N-O

PROGRAMMABLE LOCK: Output to control Maglocks or Solenoid Locks. The Maglock will be powered all the time and turn off prior to gate motion. The Solenoid mode will power a 24VDC output prior to gate motion.

AUX OUTPUT STATES:

Out 1 N-O, Out 2 N-O: Normally OPEN, Normally OPEN
Out 1 N-C, Out 2 N-C: Normally CLOSED, Normally CLOSED
Out 1 N-C, Out 2 N-O: Normally CLOSED, Normally OPEN
Out 1 N-O, Out 2 N-C: Normally OPEN, Normally CLOSED

>Output 1 Pulse Rate
2 Seconds
Output 2 Pulse Rate
¼ Seconds

OUTPUT PULSE RATE: Controls the time sequence of the pulse

Options: ¼ Second, ½ Second, 1 Second, 2 Seconds
Options: 1 Second Single

MAINTENANCE

Maintenance

GATE ORIENTATION, BATTERY STATUS, SOLAR, BATTERY CHECK, BATTERY LEVEL, OVER CURRENT LEVEL, CONSTANT PRESSURE MODE, DUAL GATE MODE & CUSTOM SETTINGS

GENESIS CONTROL BOARD

MAINTENANCE (cont.)

Batt: Float Charge
>PWR SUPPLY: Normal
Batt V Check Freq:
50 Cycles

BATTERY STATUS: Indicates the charging status:
FLOAT: When battery is FULL voltage and not being charged
BULK: Battery is in charging mode
ABSORPTION: Batteries are low, switches to charging
POWER SUPPLY VOLTAGE:

WARNING! Charging
source NOT detected
in the last 24
hours!

NORMAL (Default): Standard power supply
CHARGE: For retrofitting older systems only and replaces the original factory transformer
SOLAR: Used when you have Solar Panels

WARNING! If Solar is set to ON, and AC voltage is present, the AC voltage will not be connected and you will still be operating off batteries only!

Loss of SOLAR or Power Supply connection for 24 hours **(will cause a FLASHING ALERT warning screen)**

BATTERY V CHECK: How often the board will test the batteries under load. The factory pre-set is every 50 cycles. (Pass code required to change cycle frequency)

Additional VOLTAGE WARNINGS FAULTS & Screens: **AC is missing:** There is no AC voltage detected on the GENESIS board at the AC INPUT. **OVER VOLTAGE:** The voltage at the AC INPUT measured over the 30V in normal mode. **MOTOR OVER-CURRENT:** The motor current exceeded the high set point.

Voltage not
detected at the AC
Input

Voltage at the AC
Input measured over
30V in normal mode

Motor current went
above set point

>Low Battery Action
No Action
No Main Power Act.:
Run on Batteries

LOW BATTERY ACTION: Default is No Action

Options are:

FAIL SAFE: Gate will fail OPEN **(will cause a FLASHING ALERT warning screen)**

FAIL SECURE: Gate will fail CLOSED. **(will cause a FLASHING ALERT warning screen)**

NO MAIN AC POWER ACTION:

Options are:

RUN ON BATTERIES: If you lose AC power, your gate will continue to run on battery power

HOLD OPEN: If you lose AC power, your gate will lock up in the OPEN mode

WARNING! FAIL SAFE!
Gate held OPEN due
to critical low
battery voltage

WARNING! FAIL SECURE
Gate held CLOSED due
to critical low
battery voltage

>Low Battery Level
*Note: this screen
not viewable.
Requires passcode*

BATTERY LEVEL: During battery test, if the battery level falls below the level set, it will turn on the FAULT LIGHT and issue a FAULT CODE. (Passcode required to change). **(will cause a FLASHING ALERT warning screen)**

WARNING! LOW BATTERY
Check charge
circuit, charge or
replace Batteries

OTHER FAULT CODES:

Battery issue: Check the charge voltage, check the Batteries or replaced if necessary.

FORCED OPEN DETECT: The gate was attempted to be opened and moved off the CLOSED limit without a command from the GENESIS board.

INTERNAL EEPROM & MISSING EEPROM: Internal EEPROM missing or defective

Gate has been moved
off the CLOSE limit
w/o a command from
the GENESIS board

Internal EEPROM
fault detected

EEPROM chip not
detected

GENESIS CONTROL BOARD

>Over-Current Level :
20 Amps

OVER-CURRENT LEVEL: Adjusts the Internal Inherent Amp current level for the motor. On model 2490 systems with the GENESIS board and the LPS SENSOR, this will not be in effect. When using LIMIT SWITCHES, the OVER-CURRENT LEVEL must be set for obstruction/entrapment sensing. If the board senses an OVER-CURRENT it will reverse the gate on the first activation. On a sequential activation, this will stop the gate and turn on the UL Alarm. To reset.... Check for any obstructions, if none, Press the STOP button on the board or if you have an accessory STOP button wired to the STOP input. Other options are hit the RESET button or cycle all power off and on.

LOCKED
Key: EB60F3CA
- - - - -

CUSTOM SETTINGS: For advanced features. Requires a "PASSCODE" available from AutoGate only. Code is active for 24 hours only. After 24 hours a new code is required.

FAULT/LOGS/ALERTS

Fault/Logs/Alerts

OPTIONS: Fault log, Operation Log, Maintenance Alerts

Fault Log
>25 10:34p 04/20/18
Gate Angle Sensor

FAULT LOG: Running list of faults, stored for reference for diagnostic troubleshooting. The last 99 Faults are stored. The newest Fault will always be the first one shown. Any fault in the system will also turn on the FAULT LIGHT on the outside of the cabinet.

Operation Log
#06< 02:55p
06/29/18
Local Open

OPERATION LOG: All normal "operations" are recorded up to 99 events. (i.e. Close Limit, Open Limit, Green Open button, Red Stop button, entry Inputs, loop detections, & photoelectric sensors/beam detections, traffic lights, etc. are examples of normal "operation" events logged.)

>Maintenance Alerts
50K Cycles
Next due at 80,000

MAINTENANCE ALERT: Alerts the owner that maintenance is due after a selected number of cycles. This can be set by the installer for 10K, 20K or 50,000 cycles. The screen will show how long until the next alert will show.

>Maintenance
Required, Hold Stop
button & Press Jog
to clear.

MAINTENANCE ALERT: You have reached your predetermined number of cycles to perform general maintenance. Hold the STOP button and press the JOG/Select button to clear.

GENESIS CONTROL BOARD

FAULT LOG ENTRY	FAULT MENU DISPLAY
AC MISSING	Voltage not detected at the AC input
BATTERY LOW CHARGE	WARNING! Battery low, check battery charge voltage
CLOSE BEAM MISSING	If your "monitored" device is enabled and the required feedback (10K or Pulse) is missing
CLOSE EDGE MISSING	If your "monitored" device is enabled and the required feedback (10K or Pulse) is missing
DUAL GATE COMM. LOST	Gate set in DUAL mode: Primary or Secondary not detected
EMERGENCY SECURE	WARNING! EMERGENCY SECURE is enabled, gate will not OPEN until released
FAIL SAFE OPEN	WARNING! Fail Safe gate held open due to critical battery voltage
FAIL SECURE CLOSE	WARNING! Fail Secure gate held close due to critical battery voltage
FIRE HOLD ENABLED	WARNING! FIRE SWITCH IS ENABLED. Hold Stop and press Jog/select to clear
FORCED OPEN DETECT	Gate has been moved off the CLOSE limit position without a command from the GENESIS board
HOLD OPEN	WARNING! HOLD OPEN is enabled, gate will not close until released
INTERNAL EEPROM	Internal EEPROM fault detected
LPS SENSOR NOT DETECTED	LPS Sensor is not detected by the GENESIS board (not applicable in LIMIT SWITCH mode)
MAINTENANCE REQ'D.	Maintenance required, hold stop button and press Jog/Select to clear
MISSING EEPROM CHIP	EEPROM chip not detected
MONIT. INPUT MISSING	WARNING! Monitored input missing, see LED indicators for monitored inputs
MOTOR OVER-CURRENT	Motor current went above set point
NO CHARGE IN 24 HRS	WARNING! Charging source not detected in the last 24 hours
OPEN BEAM MISSING	If your "monitored" device is enabled and the required feedback (10K or Pulse) is missing
OPEN EDGE MISSING	If your "monitored" device is enabled and the required feedback (10K or Pulse) is missing
OVER VOLTAGE	Voltage at AC input measured over 30V in normal power mode
PGM. INPUT 1 MISSING	If your "monitored" device is enabled and the required feedback (10K or Pulse) is missing
PGM. INPUT 2 MISSING	If your "monitored" device is enabled and the required feedback (10K or Pulse) is missing
SPEED OVER-RUN	Downward speed was too fast
UL FAULT CONDITION	WARNING! DOUBLE DEFAULT. Push RED stop button or RESET button to restore to use
UL FAULT CONDITION	WARNING! OBSTRUCTION DETECTED! An intended input or RESET required to restore use

SECTION 7—ENTRAPMENT PROTECTION DEVICE INSTALLATION AND WIRING

NOTE: The operator **will not** operate without the minimum entrapment devices installed! You must have ONE Type “A” and ONE Monitored Type “B” installed in both the OPEN and CLOSING directions.

The Genesis controller is equipped with Type “A” inherent obstruction sensing and has 6 monitored entrapment inputs. The monitored inputs will be initially programmed at factory but are field selectable. There are edge and beam inputs for both “Open” and “Close” directions. **Please note that a minimum of one “open” and one “close” approved monitored entrapment device must be present along with one Type “A” device for the gate operator to function.** There are 2 programmable monitored inputs for open or close, and either can be edge or beam. All inputs are capable of 10K or 2-wire pulse, and will be programmable in the field. Any additional entrapment areas must be protected in a similar way with approved monitored devices.

APPROVED PROTECTION DEVICES FOR THIS OPERATOR

Type B1 (non-contact) devices

Open or Opening

Your Vertical Pivot operator now requires a minimum of ONE OPEN obstruction device to be wired to the Genesis Control board to operate. You may use any approved device listed below. The face and the throat area are required to be protected per UL325 7th edition.

The Genesis board supports use of a maximum of four type B1 devices.

- Open Beam
- Close Beam
- (2) Programmable Inputs

Close or Closing

Photoelectric sensors/beams should be positioned within 4” of the moving gate where risk of entrapment is identified. If using only one close beam locate within 18” of road surface.

Approved Non-Contact Devices: EMX IRB-Mon, EMX IRB-RET & OMRON EK3

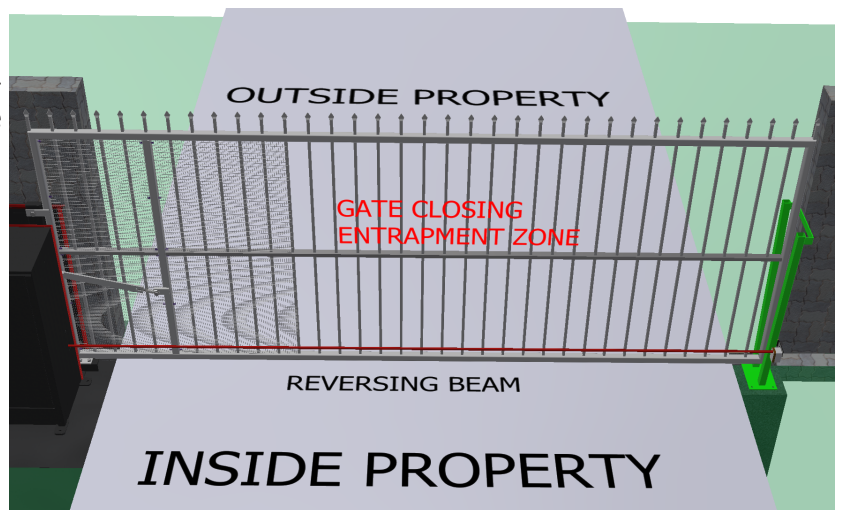

MONITORED DEVICE CONNECTIONS POINTS

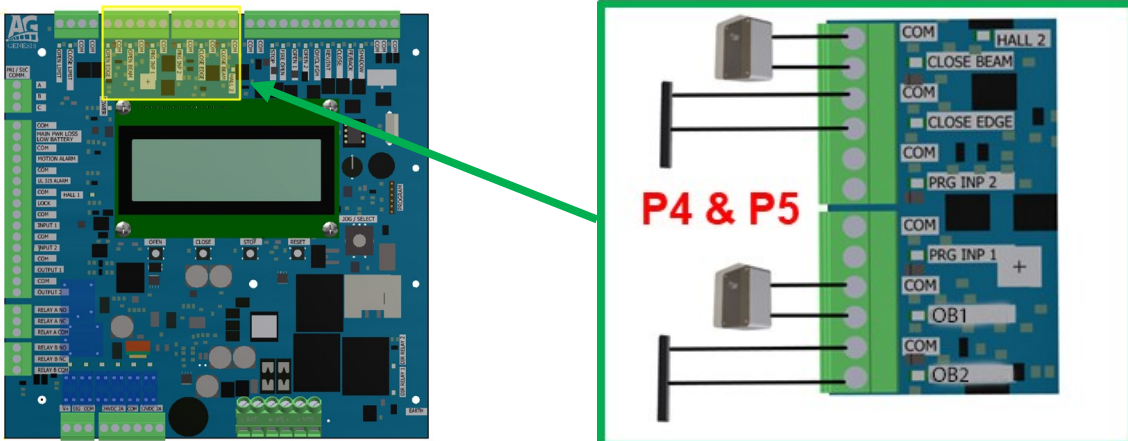

ENTRAPMENT PROTECTION DEVICE INSTALLATION AND WIRING

Type B2 (contact) Contact Sensors

Close or Closing

Contact edges on the bottom of the gate are often added as an extra entrapment device for the closing mode. We do not recommend a contact edge to be the only external entrapment device for the closing mode.

- Open Edge
- Close Edge
- Programmable Inputs (x2)

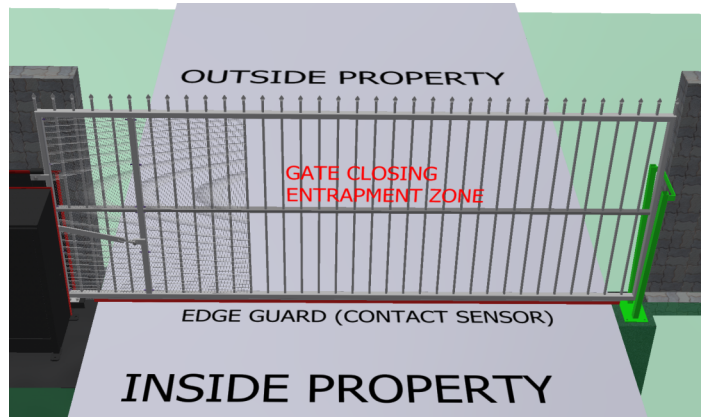

Approved Edge Sensor Devices: Miller Edge CPT 223, ASO SENTIR 15-10VT, 25.45 TT, 45 STKS4

Open or Opening

Your Vertical Pivot operator now requires a minimum of (1) OPEN obstruction device to be wired to the Genesis Control board to operate. You may use any approved device listed above. The face and the throat area are required to be protected per UL325 7th edition. The picture to the right shows (2) separate OPEN EDGES on each side of the gate running vertically down the face of the operator. The back of arm edge is on the next page. Our accessory OPEN OBSTRUCTION EDGE package includes (3) separate edges.

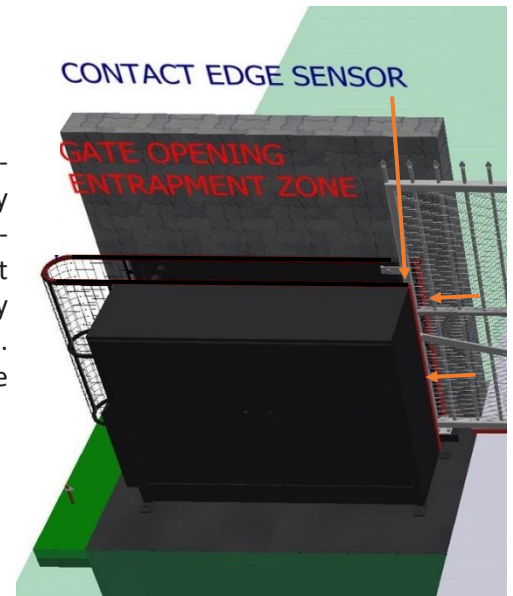

MONITORED DEVICE CONNECTIONS POINTS

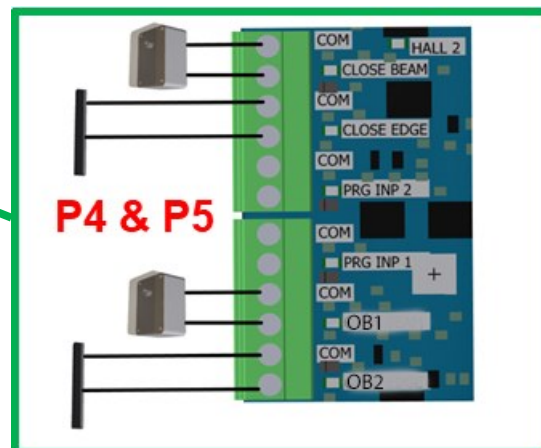
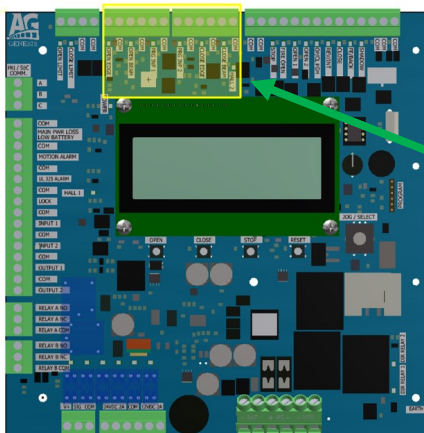

NOTE: The two programmable inputs can be configured as either edge or beam and as either open or close.

ARM OPEN EDGE FINAL INSTALLATION

ARM OPEN EDGE INSTALLATION INSTRUCTIONS

1. Remove the 3/4" nut and bolt holding the ARM OPEN EDGE to the Operator Arm (Figure 1)
2. Set the **ARM OPEN EDGE** on the Operator cabinet.
3. Discard shipping spacer
4. Install the gate to the operator arm following the instructions
5. Install the gate to the operator arm following the instructions in the I + O manual. Keep safety pin installed. Do not power on the unit and hold off on installing the 3/4" locknut(s).
6. Insert 3/4" bolt and washer
7. Place the **ARM OPEN EDGE** vertically as shown in figure 2 with the bracket and nut facing the the public/False Panel side of the gate.
8. Two bolt holes have been provisioned for to accommodate gates with extended/larger counterweights. Use the hole that will keep the **ARM OPEN EDGE** closer to the gate.
9. Apply Never-Seez to the 3/4" bolt
10. Place washer, thread 3/4" locknut and tighten down unless installing on an 8' or larger gate. In that case, loosely tighten and skip to the next step.
11. For gates 8' and taller Insert 3/4" bolt and washer into upper Operator Arm hole and apply Never-Seez to the threads.
12. Install upper brace to Operator Arm as shown in Figure 3. Loosely tighten the 3/4" locknut.

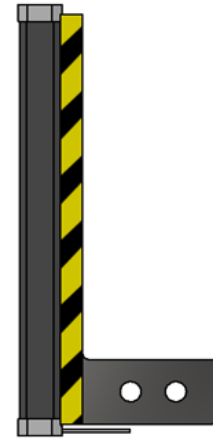

OPERATOR SKIN REMOVED FOR VISIBILITY

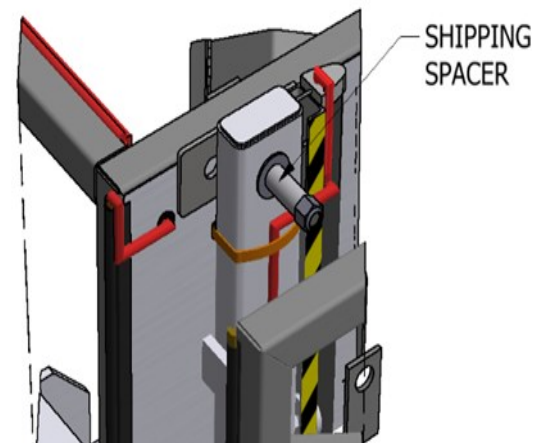

Figure 1

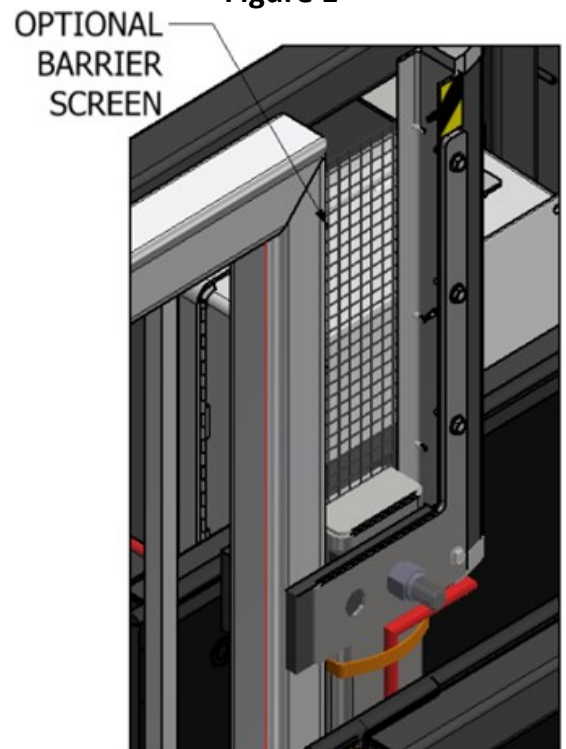

Figure 2

ARM OPEN EDGE FINAL INSTALLATION

13. Screw upper brace into **Arm Open Edge** c-channel using (2) supplied self-drilling tek screws through pre-drilled holes in the brace.
14. Tighten down both 3/4" locknuts securing gate and **Arm Open Edge** to the Operator Arm.
15. For gates without a Counterweight or with a small Counterweight leaving a gap. Place Barrier Screen in between **Arm Open Edge** and gate.
16. Secure Barrier Screen to **Arm Open Edge** c-channel using (2) supplied self-drilling tek screws as shown.
17. Restore power
18. While gate is stationary, test for proper operation by compressing the **Arm Open Edge**.
19. Observe the LED below the OB1 or OB2 port on the GENESIS control board. Illumination when compressing the **Arm Open Edge** signals proper operation.
20. Remove the Safety Pin and *manually* test gate operation while observing the Arm Open Edge wires. Ensure no wires are rubbing during operation.

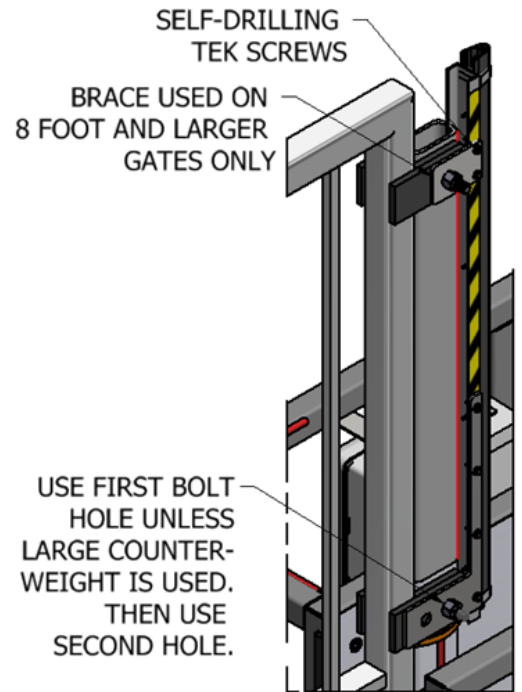

Figure 3

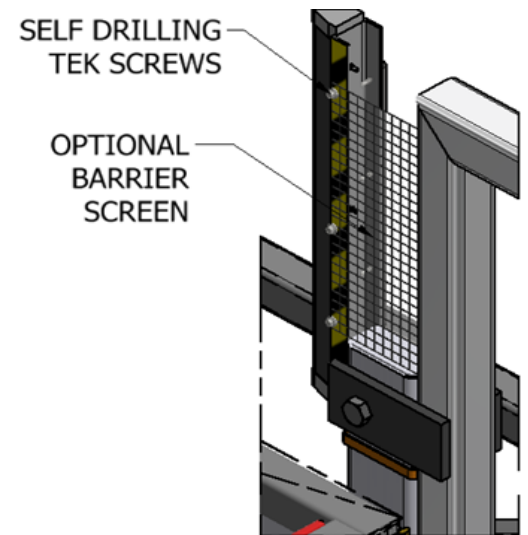

Figure 4

MONITORED DEVICE CONNECTIONS POINTS

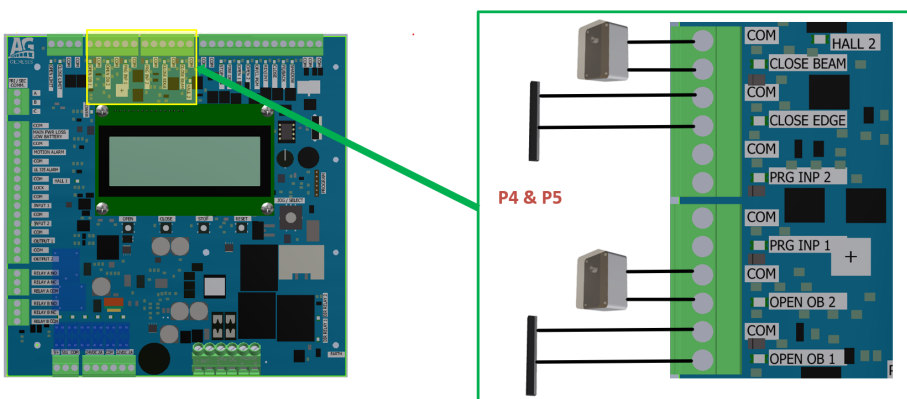

Figure 5

ENTRAPMENT PROTECTION DEVICE FUNCTIONAL CHARACTERISTICS

Monitored Open Edge	When activated, the gate will stop, (in less than 2 seconds), and then reverse and go to a full close secured position. Gate will remain closed until it receives an "INTENDED" INPUT (Keypad/Reader/Push Button/Free Exit) or the board is manually reset (Not from an Entrapment input).
Monitored Open Beam	When activated, the gate will stop, (in less than 2 seconds), and then reverse and go to a full close secured position. Gate will remain closed until it receives an "INTENDED" INPUT (Keypad/Reader/Push Button/Free Exit) or the board is manually reset (Not from an Entrapment input).
Monitored Programmable Input 1 & 2	Choice of Open or Close direction by Menu, choice of Edge or Beam and then 10K or 2 wire by Menu. <i>(Refer to PROGRAMMABLE INPUT FUNCTIONAL descriptions for required action.)</i>
Monitored Close Edge	<p>When activated the first time, the gate will stop in less than 2 seconds, and reverse to full open and allow the 'Timer To Close' to be activated upon open limit. Upon the second activation closing, before reaching the close limit, the gate will again stop, (in less than 2 seconds), and reverse to full open and the 'Timer To Close' will be deactivated. The gate will remain at full open until an "INTENDED" INPUT is activated (Keypad/Reader/Push Button/Free Exit) . The close command will close the gate and clear the hold command. An 'Open' command or a "Reverse" command, (not the Close Beam input) will trigger the reset of the 'Timer To Close' activation. Also, any of the action buttons on the control board can activate the gate, (Close button will close gate and the Open & Stop buttons will reset the 'Timer To Close' to be active).</p> <p>Note: Upon the second activation before reaching the close limit, when the gate is in the "HOLD" condition, any input that was being maintained at the time of the second activation shall be ignored until the gate is enabled by a different input! If the CLOSE EDGE remains activated, no input will release the gate for operation.</p>
Monitored Close Beam	When activated, the gate shall stop in less than 2 seconds, and then reverse to full open. The 'Timer to close' will become active only after all inputs are clear.
UL Alarm	In the event the gate receives sequential obstructions, the UL Alarm will activate. To clear, verify that there are no obstructions in the movement path of the gate. Reset the gate by pressing the STOP button on the board or pulse the STOP accessory button input. If the gate keeps stopping with alarm activation, check the balance, verify that the OVER CURRENT setting is high enough to allow normal operation of the gate. On a 2490 system, make sure the LPS is functioning properly.

TESTING YOUR OPERATOR

You are now ready to test your operator. By now you should have wired your AC and/or installed Batteries, installed **OPEN & CLOSE** Obstruction devices. ***Without your OPEN and CLOSE devices installed your gate WILL NOT OPERATE!***

Use the buttons below located on your GENESIS control board to OPEN & Close your operator.

GENESIS BOARD OPERATION BUTTONS

- **GREEN:** OPEN (Will also act as a constant pressure and override defaults to OPEN the gate)
- **YELLOW:** CLOSE (Will also act as a constant pressure and override defaults to OPEN the gate)
- **RED:** STOP (Stops the gate in either direction)
- **WHITE:** RESET (Resets the board in the event of a program change or fault)

NOTE: DOUBLECHECK YOUR AMPERAGE READINGS WITH THE FACTORY SETTINGS AND CHECK YOUR BELTS FOR PROPER TIGHTNESS (See Pg 52). BELTS MAY NEED ADJUSTING AFTER SHIPMENT.

OPERATIONAL INPUTS

In addition to the entrapment sensor inputs there are operational inputs for vehicle detection, communication with another gate or similar device as well as push buttons for control of various modes of operation.

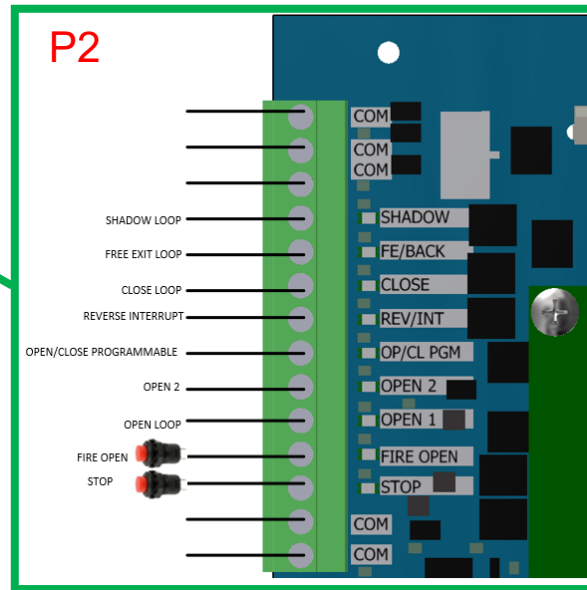
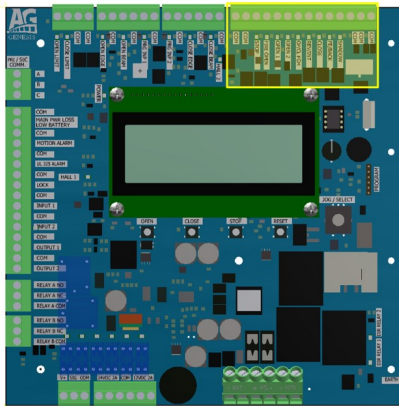

INPUT NAME	FUNCTION AFTER MOMENTARY TRIGGER	FUNCTION DURING CONTINUOUS TRIGGER
Shadow Loop	While at open limit, hold open, ignore once off of the open limit switch. <i>(Not common on Vertical Pivot Gate)</i>	Hold Open
FE/Back (Free Exit/ Back Away)	Opens gate as Open1, but when signal is removed, gate is given command to close. (Close command overridden by any other open or Reverse/Interrupt command or stop command) (Primarily designed to work with FE/Back on Barrier Arms)	Starts opening movement from any position
Close Loop	Start closing movement from any position, Open commands can override. If gate is closing when activated, gate stops until clear and then continues to close. Close input responds on release of the input normally. Close input will hold the gate open while input is maintained with the gate in the open position. When in constant pressure mode, close input responds on initial press. <i>(Not common on Vertical Pivot Gate)</i>	If held in upward motion, no effect. If held in downward motion, gate movement is paused until released and continues downward on release
Reverse/Interrupt	When closing, stops and re-opens.	If held, stay open
Open / Close PGM	When menu option not enabled, Input = open 1 only. When enabled, input = Open 1 unless the open limit is reached, it then turns to Close. If input is held during OPEN, gate holds open. Input needs to cycle off before input can CLOSE gate.	If held it remains in its state
Open 1	starts opening movement from any position	starts opening from any position
Open 2	starts opening movement from any position	Same as above
Fire Open	Absolute open, until the board is hard power reset, or local reset button pushed	Locks gate open until released
Stop	Stops gate at any point and cancels current inputs. Inputs will be ignored until stop is released. A stop input will disable the auto-close timer	If held, no gate movement, inputs ignored.

OPERATIONAL OUTPUTS

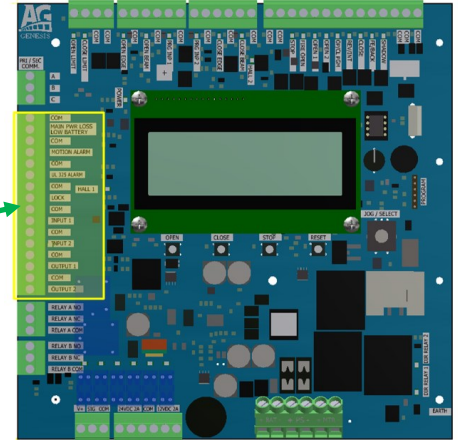
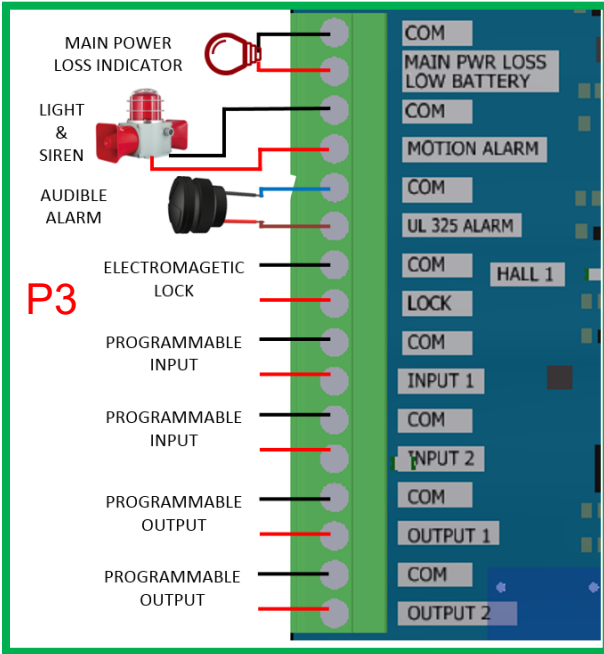

<p>Warning Light</p>	<p>Four States OFF: No faults FAST Blink: Low battery voltage DOUBLE PULSE Blink: Loss of AC power SLOW Blink: Any other fault</p> <p><i>priority for the signals are:</i></p> <ol style="list-style-type: none"> 1 - Low battery 2 - Loss of AC 3 - Any other fault
<p>Motion Alarm</p>	<p>Active for full cycle (ON-OFF menu selectable). Programmable for pre-movement opening (0-5 seconds menu selectable). Programmable for pre-movement closing (0-5 seconds menu selectable). <i>(Refer back to page 30 under TIMER SETTINGS)</i></p>
<p>UL325 Alarm</p>	<p>Active for conditions related to UL325 specifications</p>
<p>Lock</p>	<p>Programmable/Selectable:</p> <p>Magnetic lock option - Active when the gate is closed. Solenoid Interlock option - Momentary activation to open the bolt that mechanically latches the gate closed.</p>
<p>Input 1</p>	<p>OPTIONS: OFF, OPEN, CLOSE, Single Button, Reverse, Fire, Shadow, Auto Open, Hold Open, Emergency Secure, Auxiliary Pulse 1 & 2, Auxiliary Hold 1 & 2</p>
<p>Input 2</p>	<p>Same as INPUT 1</p>
<p>Output 1 (24VDC)</p>	<p>OPTIONS: OFF, Pulse on Open or Close Limit, Hold on Open or & Close Limit, Pulse on Motor Open or Close, Hold on Motor Open or Close, Hold on UL Alarm, Hold or Pulse on Motor Run, Hold or Pulse Always, Hold Not Open or Close Limit, Pulse No Open or Close Limit, Hold Not Opening or Closing, Pulse Not Opening or Closing</p>
<p>Output 2 (24VDC)</p>	<p>Same as Output 1</p>

OPERATIONAL RELAYS

P12

P13

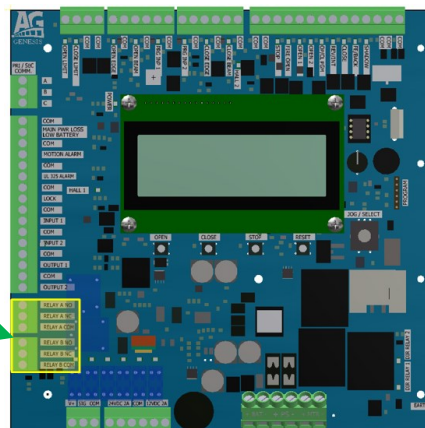
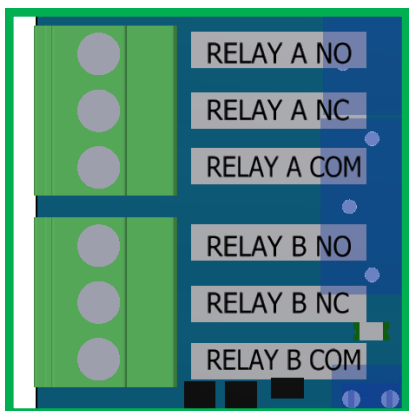

AUX Relays A & B: Are programmable for operation based on gate action or position. Both relays are form “C” relays that can be programmed to change state based on gate position or motion.

AUXILIARY RELAYS A & B

OPTIONS:

- OFF
- Pulse on OPEN Limit: 2-second Relay Activation
- Pulse on CLOSE Limit: 2-second Relay Activation
- Hold on OPEN Limit: Latches Relay ON during OPEN Limit
- Hold on CLOSE Limit: Latches Relay ON during CLOSE Limit
- Pulse on Motor OPEN: 2-second Pulse when gate starts to move OPEN
- Pulse on Motor CLOSE: 2-second Pulse when gate starts to CLOSE
- Hold on Motor OPEN: Latches Relay on when gate is OPENING
- Hold on Motor CLOSE: Latches Relay ON when gate is CLOSING

POWER FOR EXTERNAL DEVICES

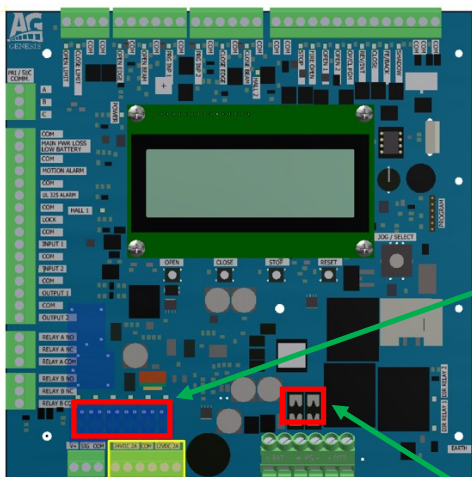

- The Genesis board has (2) 24VDC Accessory output terminals and (2) 12VDC Accessory output terminals to power external devices.
- The (2) 24VDC and the (2) 12VDC terminals are fused at 2 amps each and a total of 2 AMPS are available for the 24VDC and the 12VDC.

FUSE BLOCK-(6) 2-AMP fuses for Accessory Power

- F1**-24VDC Accessory Power
- F2**-Motion Alarm
- F3**-Main Power Loss-Low Battery/UL325 ALarm/Aux 1
- F4**-Aux 2/Programmable Lock
- F5**-Connector P14 (Pin 2) for Loop Rack Board
- F6**-12VDC Accessory Power

FUSE BLOCK-(2) 20-Amp fuses for DC power

- F7**-DC Batter Power Input
- F8**-DC Main Power Input from Power Supply

P9

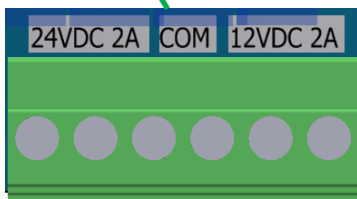

24VDC	ACCESSORY Power	(2) Fused at 2 Amps total
12VDC	ACCESSORY Power	(2) Fused at 2 Amps total

COMMUNICATIONS AND POSITION SENSOR

Primary/Secondary communications allow for communications between gates for Dual Gate configurations.



PRIMARY/SECONDARY OR DUAL GATES

When using two gates to cover a driveway and they both need to cycle together on an open input. We highly recommend using a 18ga., 4-conductor Shielded **“Twisted”** pair of wires. One set of the twisted pair to **“A”** & **“B”**, One of the second twisted pair to **“C”**. Only connect **ONE** end of ground wire to a true earth ground, cut the other end off flush and cap. Set the following board parameters:

```
>Dual Gate Mode:
  Primary
  Status:
  Disconnected
```

P/S: Set one gate for **Primary**, one gate for **Secondary** communication. Gates need to communicate with each other to work properly.

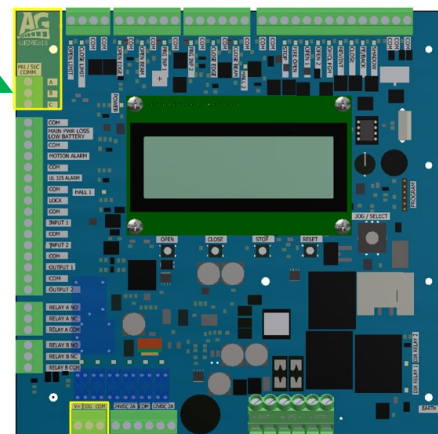

- If using the **“Auto Close”**, only set the **PRIMARY** **“Auto Close”** to on, *leave the Secondary off*
- Make sure both gates are powered up, otherwise you receive a **“communication”** error message: **Dual Gate Mode Communication Lost**. Gates will not operate in DUAL gate mode unless BOTH are powered up and connected.

LIMIT/POSITION SENSOR (LPS)

Your gate is equipped with a LIMIT/POSITION SENSOR. It will be properly set when it leaves the factory. If you need to adjust it, refer to the instructions below. If you need to replace, contact AutoGate.

ADJUSTING THE LIMIT/POSITION SENSOR

```
>Op:4500 Ramp:4000
  Gate 1
  Cl:430 Ramp:950
  Op Sp:10 Cl Sp:10
```

WARNING! This screen requires a PASSCODE to access.

1. In programming mode, Set your cursor to the GATE (line 2) and enter (>Gate). Using the Jog knob you can slightly adjust the OPEN or CLOSE position by turning it left or right.
2. Once you have readjusted your gate position, **“enter”** again to back out of the Gate line and go up to the **Op:** line or down to the **Cl:** line to set your new numbers.
3. **“Enter”** (Op or Cl) and turn the jog knob to the new numbers and test your gate.

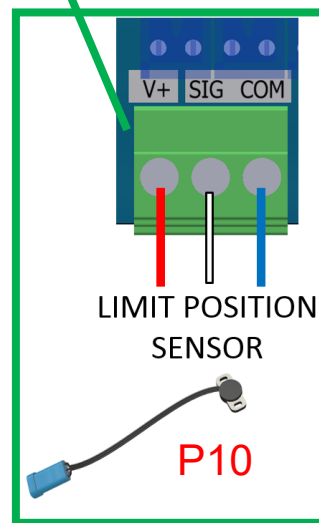

```
Fault Log
>99 02:32p 05/03/19
Over-run
```

OVER-RUN ERROR: Gate Speed is faster than the internal MAX speed. Check the Balance and the belts for slippage, adjust if necessary.

SECTION 8-GENESIS FREQUENTLY ASKED QUESTIONS (FAQ'S)

Q. My gate will not move, and the ALARM is sounding, what should I do?

A. The gate is in the UL Fault mode. Verify that there are no obstructions in the movement path of the gate. Reset the gate by pressing the STOP button on the board or pulse the STOP input. If the gate keeps stopping with alarm activation, check the balance, verify that the OVER CURRENT setting is high enough to allow normal operation of the gate. On a 2490 system, make sure the LPS is functioning properly.

Q. What kind of power does the Genesis board run on?

A. The Genesis board runs from a 24 volt DC power supply and 24 volt battery back-up. Genesis can run directly off solar panels. The gate motor runs off the batteries and the Solar Panels will keep the batteries charged. The charging circuit is integrated on the board.

Q. How much accessory power is available?

A. The Genesis board has both 24 volt DC and 12 volt DC accessory power available. A total of 2 amps are available at 24 VDC. A separate 2 amps are available at 12 VDC.

Q. Does Genesis have monitored inputs for "Entrapment Protection"?

A. Yes, there are 6 monitored inputs. Two dedicated inputs for the closing direction, (1-beam, 1-edge), and two dedicated inputs for the open direction, (1-beam, 1-edge). There are two fully programmable inputs that can function in either direction and for either type of device. These inputs are capable of monitoring 10K ohm devices. **Note: there must be at least one (1) device connected in both the open and close direction in order for the gate to operate.**

Q. Is there a way to monitor the gate position, (Open or Closed)?

A. Yes, there are 2 Auxiliary relays on the board which can be used. Also there are 2 Auxiliary Outputs which can output 24 Volts DC to accessories when open and/or closed.

Q. Can the board control external devices, such as traffic lights, counters, and other options?

A. Yes, the 2 Auxiliary relays are programmable to trigger based on gate position and/or motion.

Q. Can the speed of the gate motion be controlled?

A. Yes, the speed of the gate can be controlled separately in both directions. The adjustment will be from 100% to 75%.

Q. Why is the Green LED light flashing?

A. The green flashing LED signifies that the processor is powered up and working. If LED is on steady or OFF, the processor has a problem and the board needs replaced.

Q. System is completely dead and will not operate, how do I open the gate?

A. In a catastrophic failure (blown board, total power loss, etc.), pull the release handle on the bottom of the motor drive mechanism to disengage the drive coupler. Then at the gate, lift the Linkage Arm slightly upwards. The springs will start to pick the gate up. Then, push up on the bottom of the gate until fully open. Insert the T/M pin to lock open (Refer to Page 19).

FREQUENTLY ASKED QUESTIONS (FAQ'S)

Q. What is the difference between the “FAULT” log and the “OPERATIONAL” log?

A. The “Fault” log will store failures that are not part of standard operations. This includes things like no device connected to an active monitored input, or loss of voltage from the power supply, low battery voltage during the battery test, etc. The Operational log records all input actions, like the Open Input activation, or a monitored device is activated. This log also records the actions like close activation from the auto timer. See the FAULT LOG page for all codes.

Q. Can I download the logs?

A. Yes, the logs will be available to download by the USB port. **(Not Available yet! Coming soon)**

Q. My gate is not working, and a row of LED's is flashing?

A. The row of flashing LED's indicates the control board is in a programming mode and will not allow the gate to move. The control board will automatically cycle out of programming mode after 1 minute of no activity by the Jog/Select knob.

Q. What do I do if the “Main Power Loss / Low Battery” LED is flashing?

A. This LED is a multifunctional indicator. There are 3 flash rates that will display. If the LED is flashing, there is either a “Main Power” loss, a “Low Battery” condition, or a system fault. Open the outer cabinet door and look at the control board, a “Fault Screen” will display the current situation or fault.

Q. My gate closes too fast. How do I slow it down?

A. There are several possibilities:

1. The gate may be out of balance (See page 49). Once the gate has been rebalanced or determined to be “In” balance, if necessary, the closing speed can be adjusted.
2. Adjust the slowdown time longer
3. Change the overall running speed of the gate in the closing direction

To access these adjustments will require a PASSCODE. Adjusting the “DECEL” rate shorter will slow the gate down faster, thereby slowing the overall speed. To adjust the closing speed, access the screen showing the gate speed, which will have both Open & Close speed adjustable. The speed will be adjustable from 85% to 100% in 5% increments. Our recommendation would be to slow the gate down to 95% and test. This will normally be enough for most installations. If necessary, adjust to 90%.

Q. Why won't my gate run in it is in programming mode?

A. This is a safety feature. Sudden gate motion while programming could cause a unintended reaction by the service technician that could lead to an injury. The only time the gate can move in program mode is during the program screen while setting Limit Switches. There is the ability to move the gate in minute increments by turning the JOG/SELECT knob while the “GATE” option is chosen on the screen.

Q. Can I hang anything on my gate?

A. Yes, but you need to be careful of the weight and size of any signs and the placement of them. The gate will tolerate an additional 4-6lbs.

TROUBLE SHOOTING THE GENESIS BOARD

No power to control board	<ul style="list-style-type: none"> • Verify power switches are “ON”. • Check 20 amp fuses on control board. • Check 10-amp fuse next to power switches on battery shelf. • Check wires and connections at power supply & batteries. • Verify AC power to AC receptacles.
Gate will not operate	<ul style="list-style-type: none"> • Make sure Limit/Position Sensor (LPS) is connected and Genesis can see the signal. • Verify that there is at least one monitored device in both the open and close direction connected and operating correctly. • Check that both the batteries and power supply are on and the correct voltage is available to the board. • Check wiring connections at the motor; verify they are clean and tight. • Make sure the motor manual operation release disconnect is engaged for operation.
Gate starts to move then stops and/or reverses	<ul style="list-style-type: none"> • Verify motor over current value is set properly. • Check and adjust gate balance. (Page 49) • Verify the Limit/Position Sensor (LPS) is functioning properly • If gate reverses when closing, check for any input or a “Close Entrapment” input activation. • If gate reverses when opening, check for any “Open Entrapment” input activation.
Gate will not close	<ul style="list-style-type: none"> • Check operation inputs for activation, clear as necessary. • Verify “Close Monitored Inputs” are connected properly and functional. • Check for Reversing or Free Exit loop or detector fault. • Clear “HOLD OPEN” or “FIRE INPUT” command.
Gate will not open	<ul style="list-style-type: none"> • Verify “Open Monitored Inputs” are connected properly and functional.
Gate opens, will not time out to close	<ul style="list-style-type: none"> • Verify “Auto Close” is on. • Use “Close” command to close gate. If gate closes, gate was in second close edge obstruction and was awaiting an input to activate motion.
Alarm is sounding and gate will not run	<ul style="list-style-type: none"> • Gate is in UL Alarm lock out – Press the “STOP” button to clear alarm; Verify there is no obstruction in the gate path. If alarm keeps coming on, rebalance gate and check OVER CURRENT setting.
Batteries will not charge up	<ul style="list-style-type: none"> • If running on the AC Power Supply, make sure the board is not set for SOLAR operation. Verify that the power supply has an output voltage of $26.5 \pm .5$ volts. • If running on SOLAR panel(s), make sure board is set for SOLAR operation. Verify the panel(s) have an output greater than 31 volts DC.
Red LED light on side of Cabinet is flashing	<ul style="list-style-type: none"> • The RED LED is a warning light. If flashing, indicates a fault or failure. • Fast Flash – Low Battery • Double Pulse Flash – Main Power input Missing • Slow Flash – Fault or UL Alarm
Over-Run error Code displayed	<ul style="list-style-type: none"> • Gate speed is faster than the internal MAX speed. Check the balance and the belts for slippage, adjust if necessary.
Gate shows UL Double Fault-No obvious obstruction	<ul style="list-style-type: none"> • Check Balance! • Cycle gate and watch for sudden reversal before reaching “Open Limit” or “Close Limit”. If gate reverses direction then stops before reaching limit in opposite direction and sets off UL Alarm, adjust slow down speed a little faster. Gate is going to slow and acts like an obstruction is occurring.

SECTION 9-MAINTENANCE

The basic electrical and mechanical systems require only minimum routine maintenance. The following items should be checked and serviced periodically depending on amount of use. Each item below has supporting illustrations and/or instructions in this manual. Contact AutoGate for any questions or issues. **Maintenance is important to any gate system and can affect safety, warranty, quality operation, and life-cycle of the system.**

REFER TO OPERATOR DETAILS PAGE 10 AND MAINTENANCE OPERATOR DETAILS ON PAGE 43

ITEM	RECOMMENDED MAINTENANCE
Grease Linkage Assembly (“LUBRIPLATE ‘R’ LOW TEMP” Grease)	10,000 cycles or 6 months
Grease all bearings: two (2) Operator Arm, four (4) Bullwheel Shafts	10,000 cycles or 6 months
Grease Chain Tension Bolt and Lube Chain & lightly coat springs (Use a non-evaporating cable and chain spray)	10,000 cycles or 6 months
Check belts for wear and tightness. (See page 47 for instructions)	Every 6 months
Charge voltage for batteries should be 27.5 VDC with batteries disconnected check at battery in maintenance menu.	Every 6 months
Check battery water level, use distilled water only (Not required on maintenance-free or AGM style batteries)	Every 6 months
Clean snow/ice off of gate (Balanced correctly, gate will temporarily tolerate an additional 10 lb. of wt.)	As needed
Clean lenses on Photoelectric sensors/beams or Reflectors	As needed
Lubricate (Graphite Oil) all door latch, lock cylinders and mechanisms	Every 6 months
Check and verify proper operation of all External monitored entrapment protection devices. See page 35-36 and the external entrapment protection device(s) manufactures instructions.	Every month
Check and verify proper operation of the Internal (TYPE A) entrapment protection device (LPS) by walking to the middle to end of the gate and stop the gate, it should reverse.	Every month
Check gate balance (see page 49)	Four months after install, then annually
Check to make sure all WARNING signs are still displayed	Every month

MAINTENANCE OPERATOR DETAILS

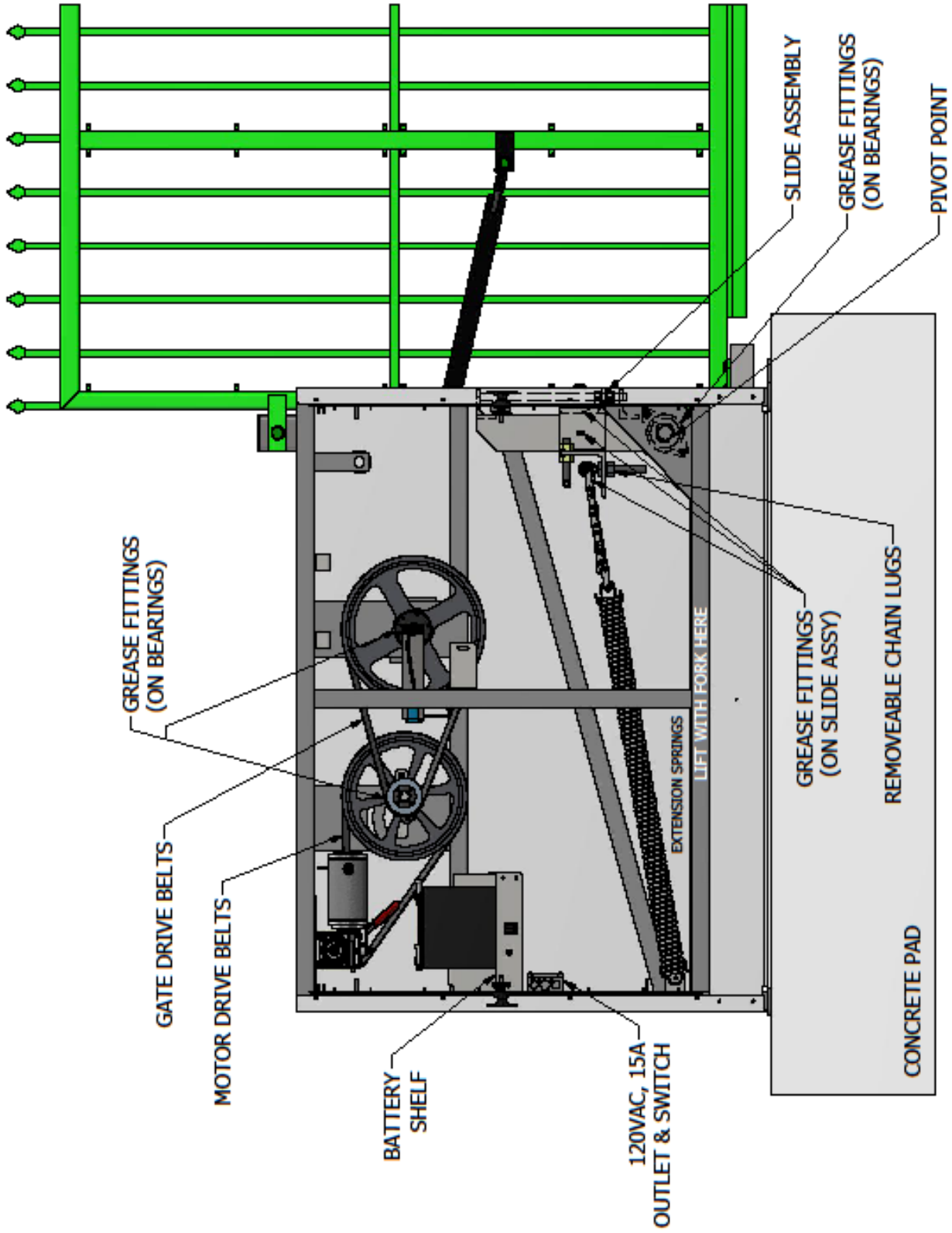

Note: P/M Details only, see other pages for details on electronics and accessories.

ELEVATION VIEW

BELT CHANGING INSTRUCTIONS

Changing the belts on an AutoGate Vertical Pivot operator is easy by following the step by step procedure outlined below. As always, we are only a phone call away should you need assistance at 800-944-4283.

1. Remove the **(4) Tek Screws** on the **Top Panel** using a 5/16" nut driver, remove and set aside.
2. Remove the **STIFFENER PLATE (#1)** from the **POSITION SENSOR bracket**. This allows a space to remove belts.
3. Release the **MOTOR DRIVE BELT (#2)** tension by loosening the **(4) 3/8" CARRIAGE BOLT nuts** securing the **GEAR MOTOR bracket (#3)** to the **SIDE SLIDE plates (#4)** with a 9/16" wrench. Now using a 9/16" wrench, back off the **(2) Gear Motor FORCING screws (#5)** so that only 1" remains through the coupling nut.
4. Slide the **GEAR MOTOR assembly** to create slack in the belts.
5. On the center of the pulleys. Loosen the **FLANGE BEARING bolts (#6)** about one turn that secure the shaft bearings using a 15/16" wrench.
6. Loosen the **MIDDLE FORCING screw (#7)** which is applying tension on the **GATE DRIVE belts (#8)** by using a 15/16" wrench. This too needs to be fully loosened to allow enough room to remove the belts.
7. Remove old belts and install new belts loosely.
8. Apply snug pressure to the **MOTOR DRIVE belts** by using the **(2) GEAR MOTOR FORCING screws**. This should also snug the **GATE DRIVE belts**. **Do not overtighten!**
9. Thread the **MIDDLE FORCING screw** to finger tight.
10. Re-Assemble the **STIFFENER PLATE** to the **POSITION SENSOR bracket**.
11. Operate the gate up and down for (5) time to seat the belts.
12. Tighten the **MIDDLE FORCING screw** to tighten the **GATE DRIVE belts**. Correct tightness is 10lbs. of pressure applied at the center of belts with a 1/4" deflection.
13. Tighten the **FLANGE BEARING bolts** on the middle set of pulleys.
14. Tighten the **GEAR MOTOR FORCING screw** to achieve 1/4" -1/2" deflection with 10lbs. of pressure applied at the center of the belts.
15. Tighten the **(4) CARRIAGE bolts** to secure the **GEAR MOTOR bracket** to the **SIDE SLIDE plates**.
16. Operate the gate up and down 5-10 times to check for proper operation.
17. Replace the **Top Panel** using the (4) Tek screws.

BELT TIGHTENING INSTRUCTIONS

- | | |
|---------------------|------------------------------|
| 1. Stiffener Plate | 5. Gear Motor Forcing Screws |
| 2. Motor Drive Belt | 6. Flange Bearing Bolts |
| 3. Gear Motor | 7. Middle Forcing Screw |
| 4. Side Slide | 8. Gate Drive Belts |

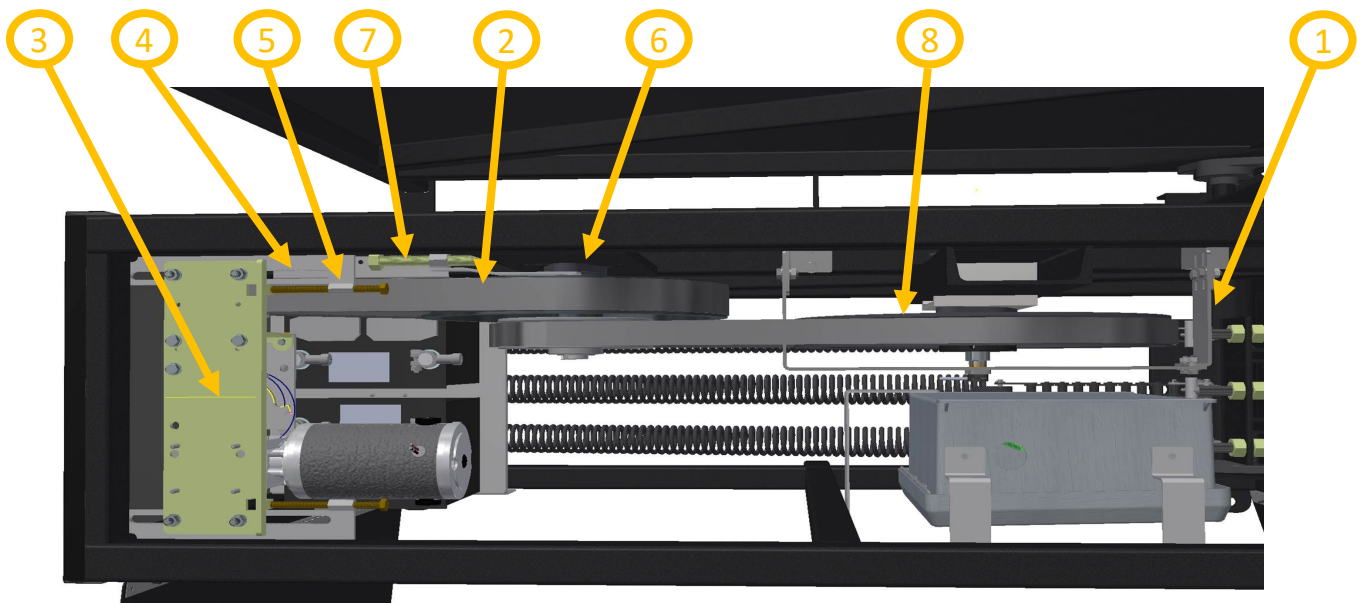

SPRING CHANGING INSTRUCTIONS



WARNING: SPRINGS ARE UNDER A TREMENDOUS LOAD. TAKE EXTREME CAUTION WHEN REMOVING AND REPLACING THEM.

TOOLS REQUIRED: 5/16" (Nut Driver), 1/2", 1 1/8", 1 5/16" Open End Wrenches

STEPS:

1. For ease of access, remove the door and end panel nearest the gate.
2. Disable the photoelectric sensor/beam if equipped.
3. Remove any upper "T" bolts completely and loosen the slide assembly screws.
4. Loosen the top adjusting nut of the slide assembly. Thread the nut up to within four (4") inches of the top of slide mechanism.
5. You will now raise the gate. (**DO NOT** release the disengage lever!) Initiate the gate to open, immediately move to the gate and help raise it open, once the slide moves up, hold on the bottom rail of the gate until fully open. The gate may bounce slightly, there will be a loud bang but no damage will occur.
6. Turn Off AC/DC Power before gate "times out" and tries to close. Insert T/M Pin.
7. Using a 1 5/16 wrench, loosen and remove the chain tension bolt with the damaged spring.
8. Replace damaged spring
9. Replace chain tension bolt. **NOTE:** Grease fitting must point down! Tighten bottom nut. **NOTE:** Chain **MUST** remain level and not twisted once tightened.
10. Remove T/M pin and restore AC/DC power.
11. Lowering the gate. Initiate the gate to close and at the same time, assist the gate down by pulling on the bottom rail of the gate. The slide will move down and another loud bang as the gate is lowered.
12. Turn off AC/DC power.
13. Thread the slide nut back down to the slide assembly and tighten.
14. Replace the T-Bolts to their original location and tighten and tighten the slide assembly screws.
15. Restore AC/DC power and hook photoelectric sensor/beam back up.
16. Cycle gate.

17. Spray all springs with a chain lube to prevent corrosion.

18. Grease Chain Tension bolts, Linkage Arm & Bearings

RECOMMENDED: Always check and adjust the balance after any spring change. Refer to balancing instructions at www.AutoGate.com or the instructions on Page 49

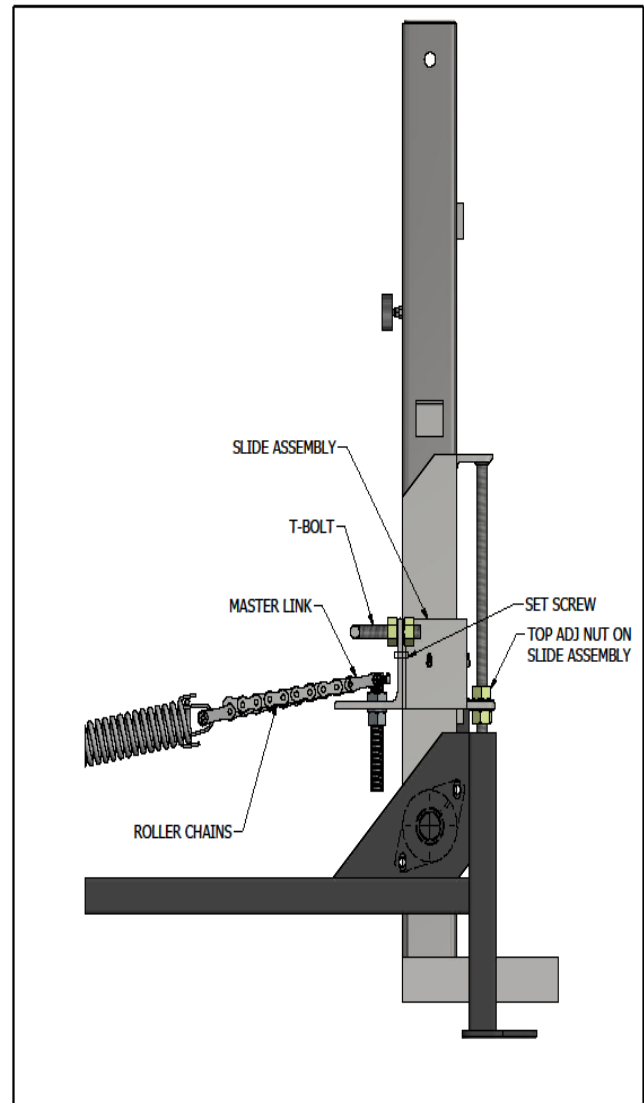

BALANCING

TESTING AMPERAGE

1. Connect AMP meter in series by removing the wire nut from the **RED** motor lead.
2. Cycle gate up and down recording the highest amperage in the space provided and adjust in necessary. highest UP and DOWN readings should not exceed a 1 AMP difference. For example: if your highest reading is 6.5 UP and 6.0 DOWN, that would be acceptable. Unacceptable would be 3.1 UP and 8.0 down.

ADJUSTING:

1. Loosen the set screws on the Slide Assembly as well as the 1 1/8" nuts on both sides (top & bottom) of the Slide Assembly Angle.
2. Only adjust the nuts 3 to 4 turns (1/4") at a time and check your amperage readings after each adjustment.
NOTE: your amps in the OPEN mode should be approximately .5 (1/2) amp higher than the CLOSE amperage.
3. If the gate opens too slow and is drawing high amps, raise the Slide Assembly and recheck. If the gate will NOT close, lower the Slide Assembly and re-check. If your gate stalls in either direction, you have over-adjusted. Back off the last adjustment and re-check.
4. If the gate is slow starting to close from the open position, increase the length of the T-Bolt (s).
5. Tighten Set Screws and 1 1/8" nuts.

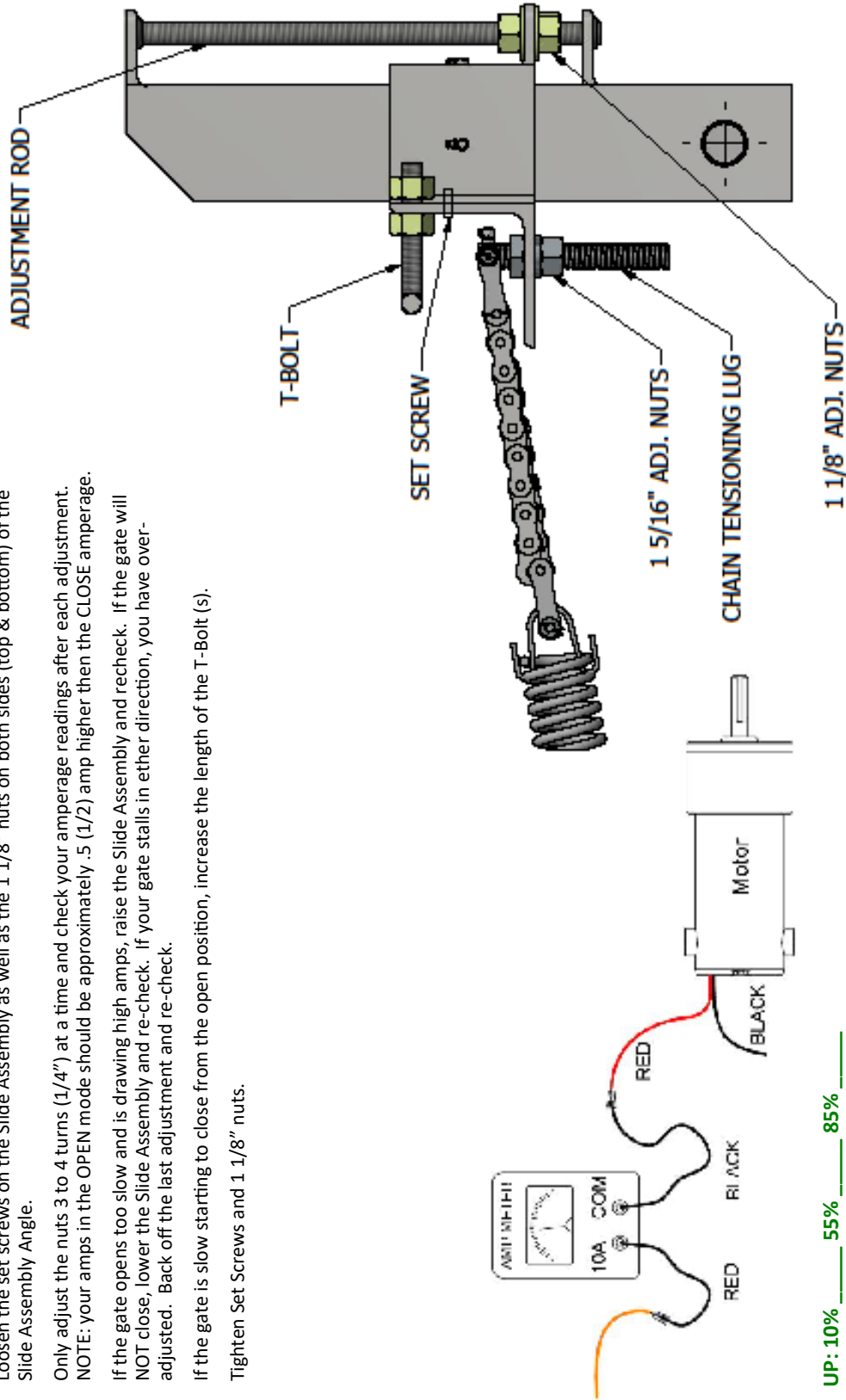

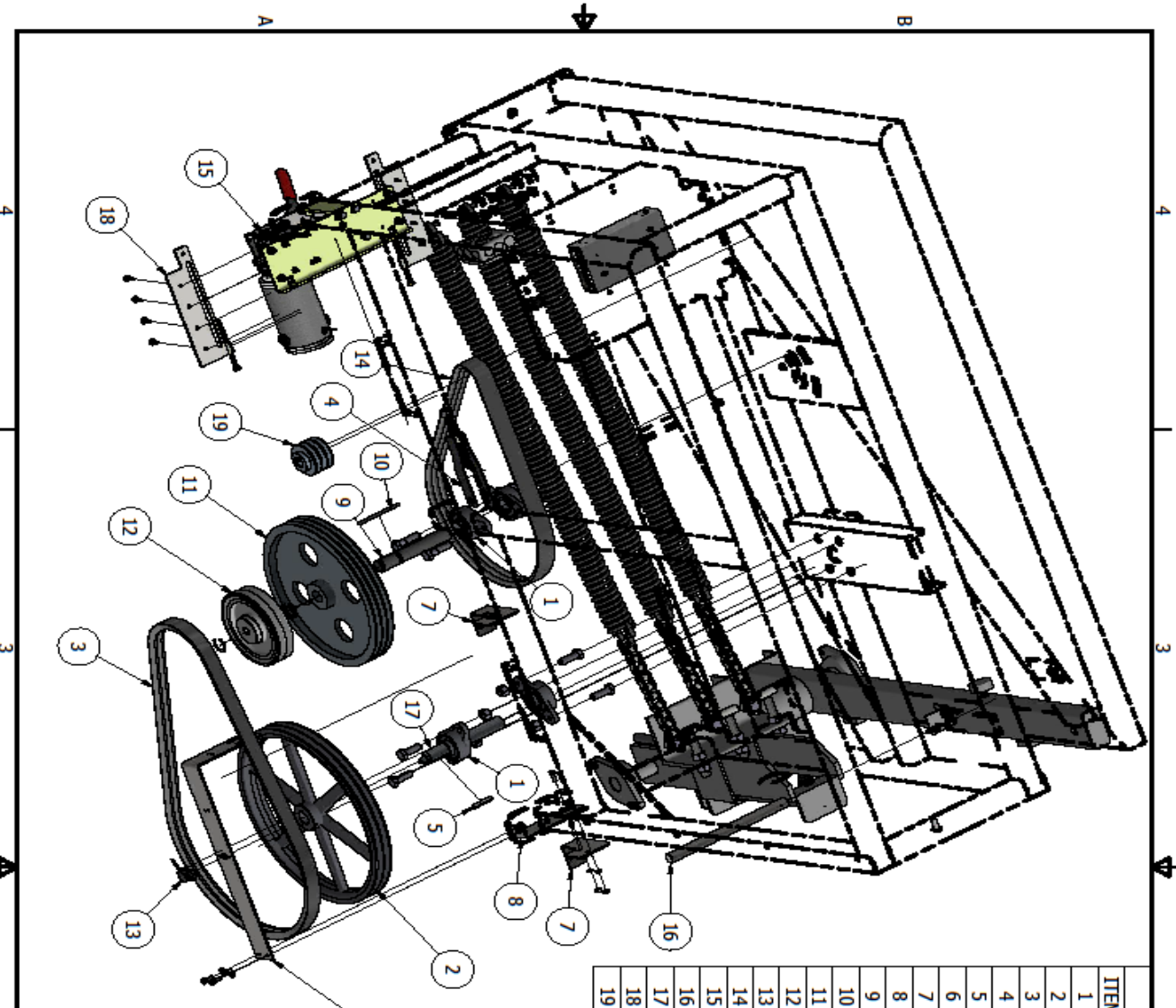

ITEM	QTY	PART NUMBER	DESCRIPTION
1	4	H-0150	Flange Bearing -- 1-1/4" #206
2	1	H-0564	SHEAVE - MAIN BULLWHEEL-18.4"
3	1	H-0606	V-Belt -- Banded/COG-- #2/BX79
4	1	T-0567	Belt Tensioner Arm Weldment
5	2	H-0588	KEY MAIN BULLWHEEL
6	1	T-0850	LIMIT POSITION MOUNTING BRACKET
7	2	T-0852	LIMIT POSITION BRACKET MOUNT
8	1	T-0851	MOUNTING BRACKET BRACE
9	1	T-0854	AUX. BULLWHEEL SHAFT
10	4,500 In	T-0839	KEYSTOCK -- AUX. BW
11	1	H-0561	SHEAVE - AUXILIARY (LARGE)-15"
12	1	H-0562	Sheave - AUXILIARY (Small)-7.4"
13	1	M-0313	ENCODER -- W/86" CABLE
14	1	H-0565	V-Belt -- Single/COG -- #AX61
15	1	M-0429	RAD MOTOR ASSY. -- LH
16	1	T-0549	T/M SAFETY PIN ASSY -- STD
17	1	T-0853	MAIN BULL WHEEL SHAFT
18	2	T-0876	RAD MOUNTING BRACKET
19	2	H-0560	SHEAVE - 3" x 1" BORE/MOTOR

PARTS LIST

NOTICE

THE INFORMATION CONTAINED
HEREIN IS UNCLASSIFIED
DATE 08/17/2020 BY 60322
DECLASSIFY OR DOWNGRADING
AUTHORITY: 25XCFR 172.163
STANDARD (R)

NOTE: DIMENSIONS ARE IN INCHES
UNLESS OTHERWISE SPECIFIED
TOLERANCES ARE: ANGLES ±1°
X/4" ±.015" X/2" ±.02"
X/8" ±.012" X/16" ±.008"
X/32" ±.004" X/64" ±.002"

FILE: E:\3D Inventor\PROJECTS\PR-1086 OPERATOR EXPLODED VIEWS\PR-1086-OPERATOR.lam

Date: 8/17/2020	Dwg By: KD
Chk. By:	
Title: VPG2490	
Description: LEFT HAND OPERATOR ASSEMBLY	
Drawing Number: LH OPERATOR UPPER EXP VIEW	Rev:
Inventory:	Material:

