

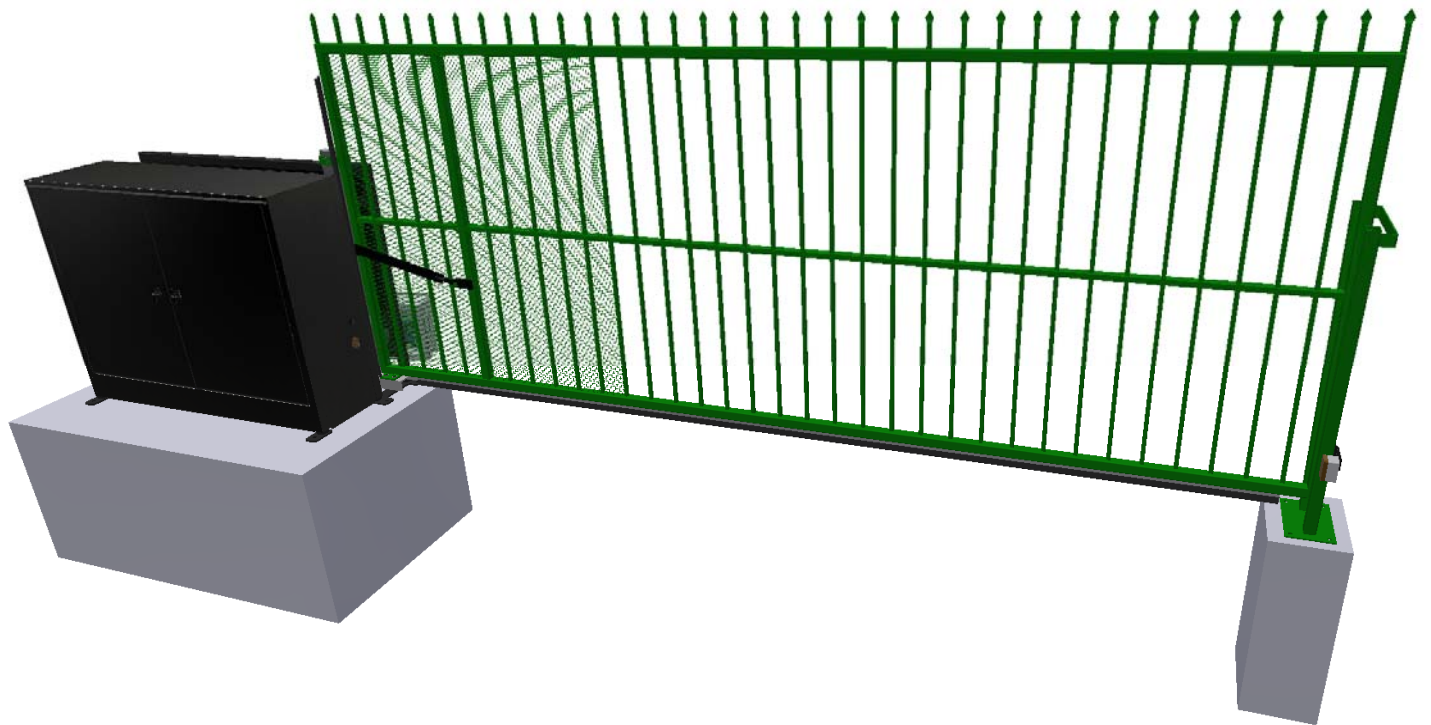

## VERTICAL PIVOT GATE OPERATOR

### 2490/GENESIS Introduction

- THIS PRODUCT IS TO BE INSTALLED AND SERVICED BY AN EXPERIENCED TRAINED GATE SYSTEMS TECHNICIAN ONLY
- This model is used for vehicular gate traffic ONLY and not intended for pedestrian use.
- This model is intended for use in Class I, II, III and IV vehicular Vertical Pivot gate applications



FULL SIZE MANUAL AVAIABLE TO DOWNLOAD AND PRINT AT [WWW.AUTOGATE.COM](http://WWW.AUTOGATE.COM)



# MODEL VPG2490

## VPG2490 OPERATOR

The VPG2490 is AutoGate's new UL 325 Rev 7 Listed Vertical Pivot Gate Operator. The VPG2490 employs a 90°, (Right Angle Drive) gearmotor, and a newly designed 24 VDC controller (Genesis Board) and utilizes a new Limit/Position Sensor (LPS) to detect gate position. The frame for this model is 2" taller than the previous model to allow for clearance between the windbracing and the end panel of the operator cabinet when the gate is fully open. This allows the addition of "OPEN EDGE" contact bump strips to be mounted around the gate throat as required by UL 325. In addition to the Gate Throat the entire "Entrapment Area" is required to have "OPEN OBSTRUCTION" protection per UL 325.

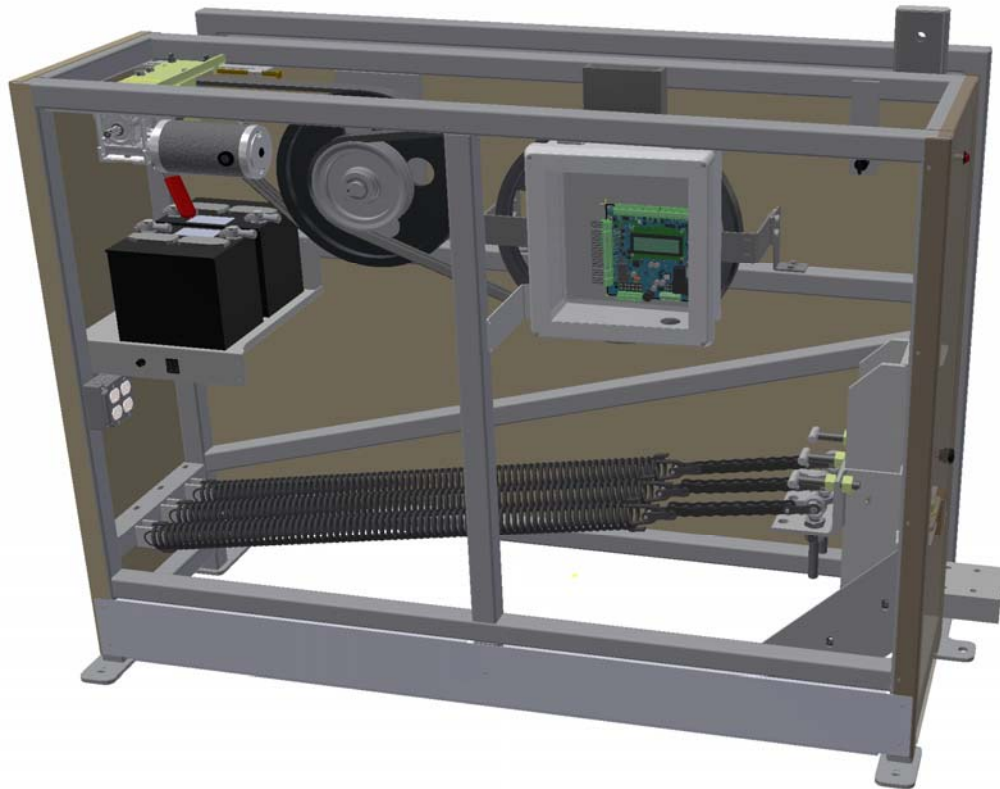

## VPG2490 BELTS

The new 90° gearmotor is a ½ horse power motor with a non-back drivable right-angle drive gearbox, and a redesigned sheave and belt configuration. The new configuration will provide better control of the gate motion and will prevent the gate from "OVERRUNNING" the motor. There will be 2 drive configurations used. The standard speed will open or close the gate in 8 to 10 seconds, including slowdown. For larger or extra heavy gates the speed will be reduced slightly to prevent excessive wear to the drive mechanism and to allow for safer control of gate motion. These systems will open or close in 13 to 15 seconds, including slowdown.

Adjustments to the drive belts are a critical part of the gate operator function. With the introduction of the ½ horse power right angle drive gearmotor, the 'MOTOR' drive belts have been changed to "A" section belts. This now requires 3 belts to handle the torque. Another reason for the size change from "B" to "A" is it allows us to get better grip with less belt wear on the small motor drive sheave. The 'GATE' drive belts will still be the "B" section belt. This will continue to be a "Banded" style belt but will be the "Notched" belt for better torque and grip.

## 2490 BELTS (cont.)

### The following are the recommended belt tension adjustments:

To obtain the measurements place a long straight edge across the span as shown by the dotted line and press down on the belt with a small force scale or fingertip at midspan between the contact points of the belt and sheaves.

The primary 'MOTOR' drive adjustment is an average of the 3 belts. Adjust to **.25"** deflection with **6 to 7 lbs.** of force. Also, when adjusting the 'MOTOR' drive belt tension, make sure to keep the motor mounting assembly square, either using a tape measure or the notches in the mounting slides. When properly aligned belt tension should be the same in all three belts.

The 'GATE' drive belt, on a standard speed system, from the intermediate sheave set to the final drive sheave is as follows; deflection of **.3"** with a **5 to 6 lbs.** of force for individual belts or **.3"** with **11 to 13 lbs.** of force for banded belts.

The "GATE" drive belt on a slow speed system, from the intermediate sheave set to the final drive sheave will have a deflection of **.3"** with a **9 to 11 lbs.** of force.

***For complete BELT CHANGING instructions refer to page 14 in this document.***

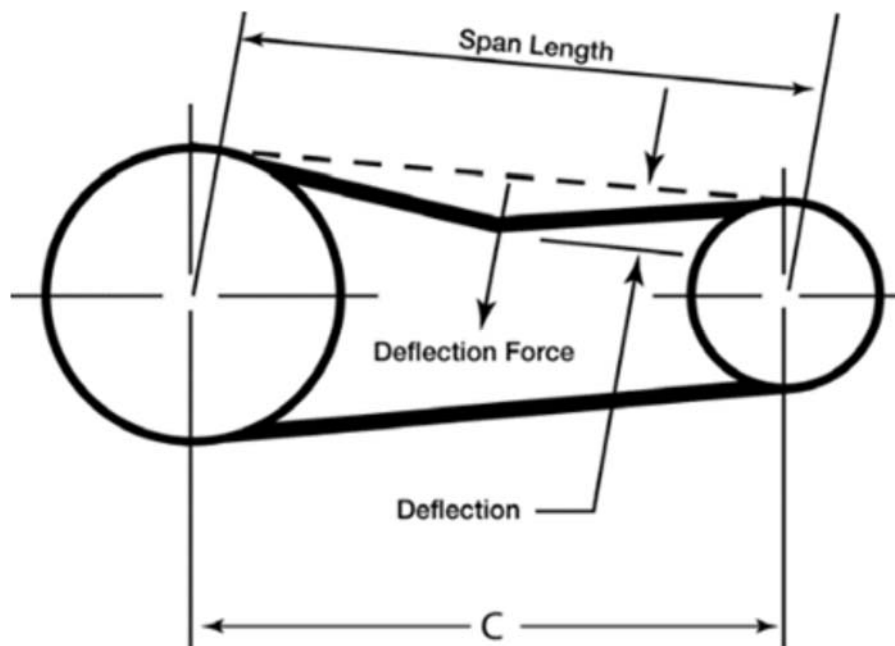

# Genesis Controller

AutoGate is introducing the “GENESIS” control board. Genesis is a 24 Volt DC board capable of controlling motors rated up to 20 Amps. The board has a 4 line, 20 characters per line display for information and programming.

The Genesis board operates on DC power. Our standard system will be supplied with a 24 to 28-volt DC / 18.8-amp power supply and the Power Supply setting will be “NORMAL”. This will power all functions of the gate. There is an internal battery charger/maintainer circuit on the Genesis board. The system will require two (2) 12-volt batteries wired in series or a single 24-volt battery connected to the battery terminals for back-up capabilities (Highly Recommended). Batteries need to be the same physical size, and the same capacity rating. The power supply has (2) voltage input settings which is controlled by a switch on the side of the case. The settings are 115 and 230. The 115-volt setting is for 90 – 132 volts AC at 10 Amps. The 230-volt setting is for 180-264-volt AC at 6 Amps.

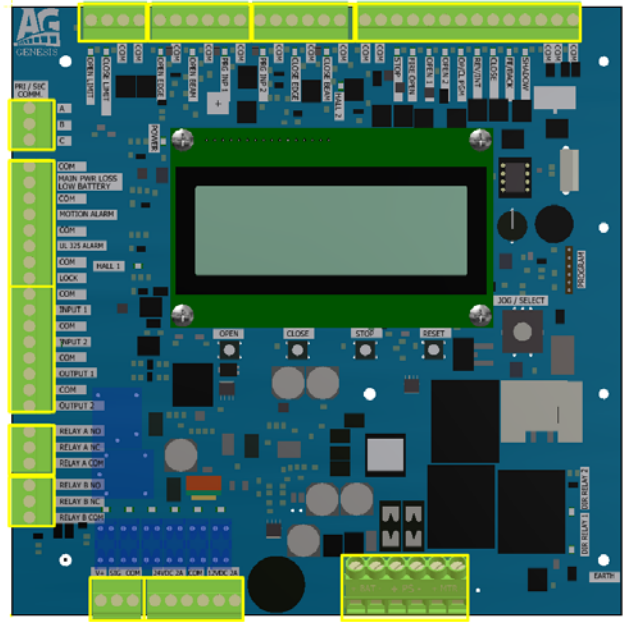

There are 2 more power input settings on the Genesis board. Both settings will require (2) 12-volt batteries or (1) 24-volt battery for gate operation. One is the SOLAR setting. When set for SOLAR, any solar array that is designed for 24-volt charging can be directly connected to the Genesis board in place of the power supply. The board will still control the gate as normal, but the motor will run from the battery/batteries. The on-board charging system will now charge the batteries from the solar panels whenever there is enough light to activate the panels.

**NOTE: (2) 12-volt solar panels wired in series, or (1) 24-volt panel, (2 24-volt panels wired in parallel to maximize output current), will produce between 31 VDC and 45 VDC. When the voltage falls below 31 volts, the circuit will stop charging and prevent current from back feeding to the panels. Make sure that the proper setting is chosen. If using the normal power supply and the board is set for “SOLAR”, the batteries will never get charged because the power supply is set to 26.5 VDC, and therefore will never reach the level required for charging per the “SOLAR” program.**

The other non-standard setting is called “CHARGE”. This will mostly be used for backwards compatibility on systems that currently use a transformer when upgrading to the Genesis. Since the Genesis board only uses DC voltage, the AC transformer will not work. By using a 36-volt 4-amp power supply, the “CHARGE” setting will work similar to the “SOLAR” setting. The power supply will output 36 volts and charge the batteries and the batteries will run the gate. But unlike solar panels, because the power supply will always be on, the charging circuit will always work. This setup is easy to convert on our older systems using the transformer as a power source.

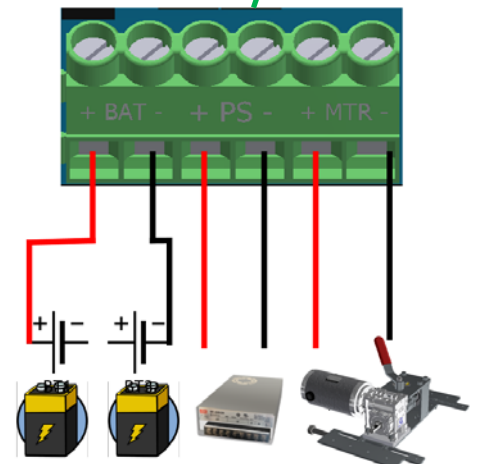
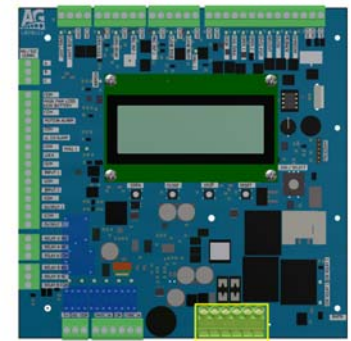

## GENESIS CONTROLLER (cont.)

The Genesis board is programmed to monitor the input power in all 3 scenarios. In normal operation, using the regular power supply, if the AC power to the supply or the power supply itself fails, the RED LED indicator light on the driveway operator end panel will flash. If the 'solar' panels or the 'charge' supply fail to charge the batteries for more than 24 hours, again the indicator LED will flash, and a warning screen will show on the 4-line display indicating that there is a problem with the solar panels, wiring, or that there is an issue with the AC power to the charging power supply or the power supply itself.

If either the 'NORMAL' or the "CHARGE" power supply have a no output condition, first try turning off the AC power switch, then after a few seconds turn the AC switch back on. If the Genesis display shows power supply voltage as normal, then there was either an overvoltage input or an over load of the amp draw on the output. The power supplies have a built-in overload protection to prevent damage to itself or the control board. If the power supply over heats, it will shut down until the temperature returns to normal then it will re-start automatically if AC power is present.

The 12 VDC terminals are for 12-volt accessories. Just like the 24-volt terminals, the commons in the middle of the block are used for the circuit. Again, both terminals combined have a 2-amp load rating.

Both the 24-volt and the 12-volt terminals are protected by a 2-amp fuse. It is highly recommended that the total load on either set of terminals does not exceed 1.75 Amps. Current draw that equals the fuse rating could blow the fuse under normal use due to fluctuations in equipment.

The last set of terminals on the board are high current load connections. Left to right are, BATT+, BATT-, 24 VDC+, 24 VDC-, MOTOR "A" & "B".

BATT+ = Battery positive wire

BATT- = Battery negative wire

24 VDC+ = Power supply positive input

24 VDC- = Power supply negative input

MOTOR "A" = Wired to the RED motor wire

MOTOR "B" = Wired to the BLACK motor wire

# GENESIS CONTROL BOARD (cont.)

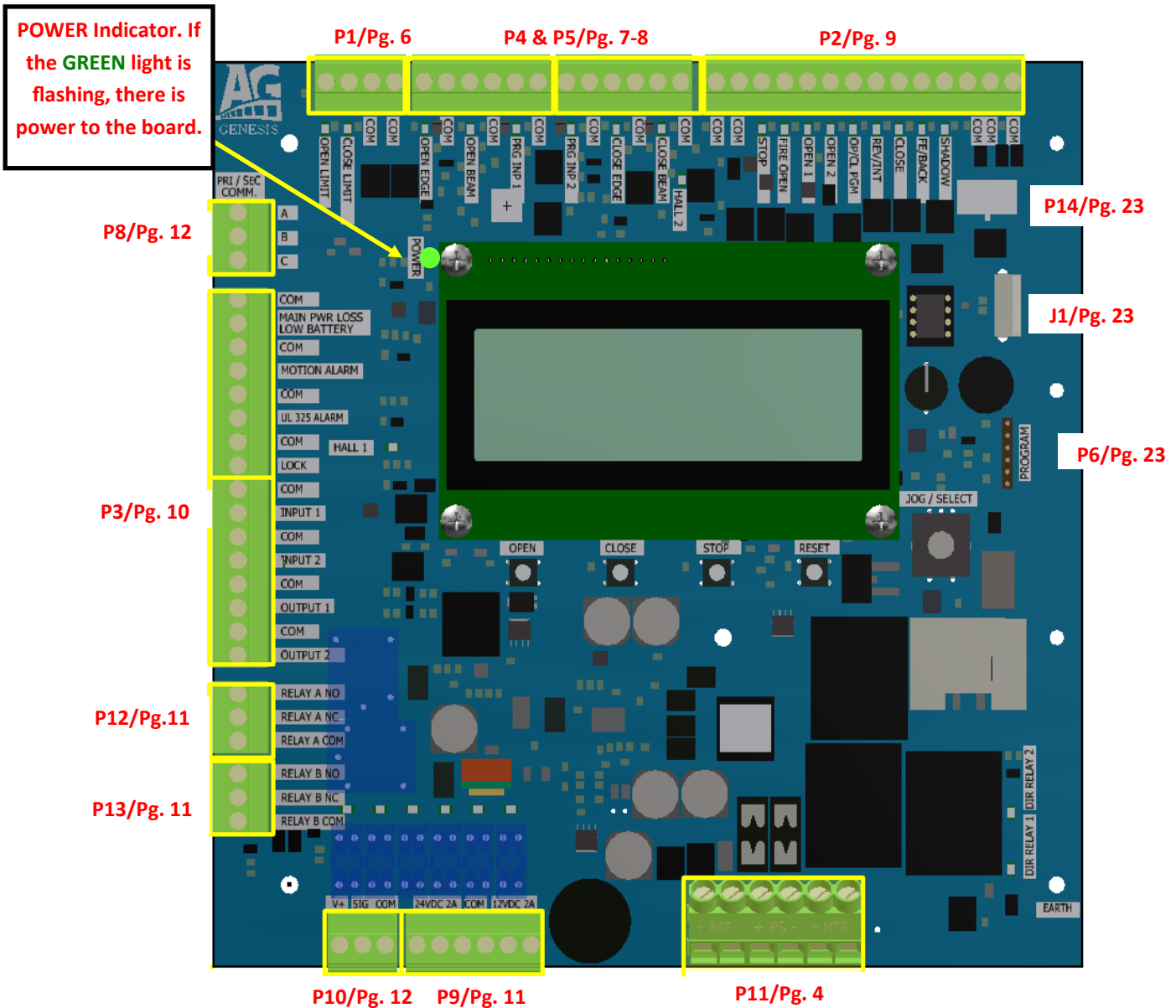

**P1**

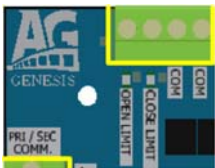

**Note:** **P1** is NOT USED on the VPG2490 model. The VPG2490 uses a **Limit Position Sensor (LPS)**. **P1** would only be used if you were to install the GENESIS board in an older operator with limit switches.

**P14**– Loop Rack Accessory Wiring harness port: Used with our LR-3 Loop Rack board

**J1**-USB For data connection (future use)

**P6**-Program Plug: Used to update board software

## Genesis Controller (cont.)

The GENESIS board is one of the most advanced boards on the market to meet all the requirements for entrapment for UL-325. Your gate will not operate without wiring in the necessary “reversing protection” equipment.

### MONITORED DEVICE CONNECTIONS POINTS

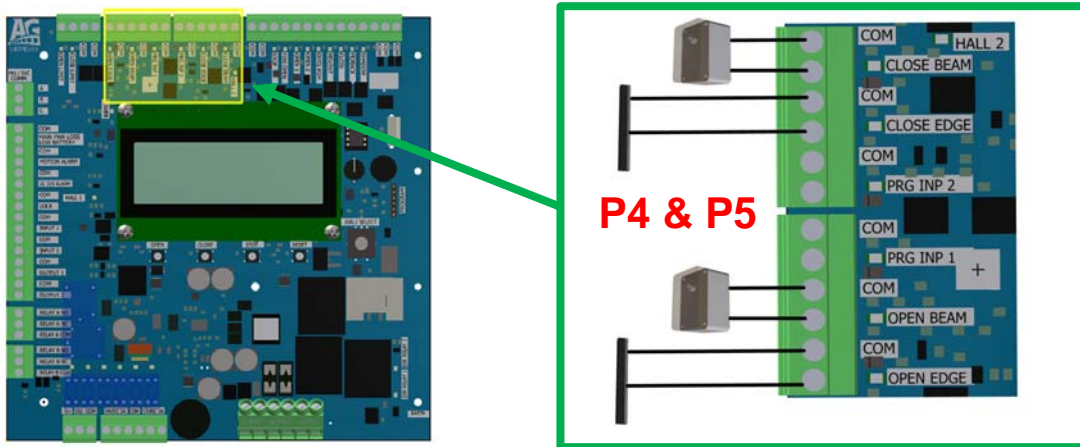

The board has been designed to meet just about any accessory device and application you can think of. Please review the next few pages for details on each board INPUT, OUTPUT, POWER and FUSING details.

### GENESIS INPUT & OUTPUT DETAILS

- Standard INPUTS for OPEN, CLOSE, STOP, Loops, Access Controls, Pushbuttons, etc.
- 6 “MONITORED” 10K entrapment device INPUTS for OPEN and CLOSE obstruction
  - Dedicated 1 BEAM and 1 EDGE “OPEN” obstruction
  - Dedicated 1 BEAM and 1 EDGE “CLOSE” obstruction
  - Two additional programmable for either OPEN or CLOSE obstruction
- Additional Programmable Relays
- Additional Programmable INPUTS
- Additional Programmable OUTPUTS
- 24VDC Fused Accessory Power
- 12VDC Fused Accessory Power

SPECIAL NOTE: The GENESIS board can be retro fit into older operators. If a Genesis board is to be used in non-monitored entrapment device gate system, the required OPEN & CLOSE monitored inputs can be deactivated. This will require a special passcode to allow the servicing dealer 24-hour access to programming that can bypass the UL Rev. 6 code. To get the pass code, a phone call to AutoGate with the gate serial number or AG # and the 8-character code displayed on the access screen. The AutoGate representative will read back a 5-character code that will need to be entered on the display. Again, this will allow 24-hour access to this special programming function. After that, if there would ever be a reason to access the special programming functions, a new passcode would be needed.

See the following pages for definitions of each terminal on the GENESIS control board.

## MONITORED DEVICE CONNECTIONS POINTS

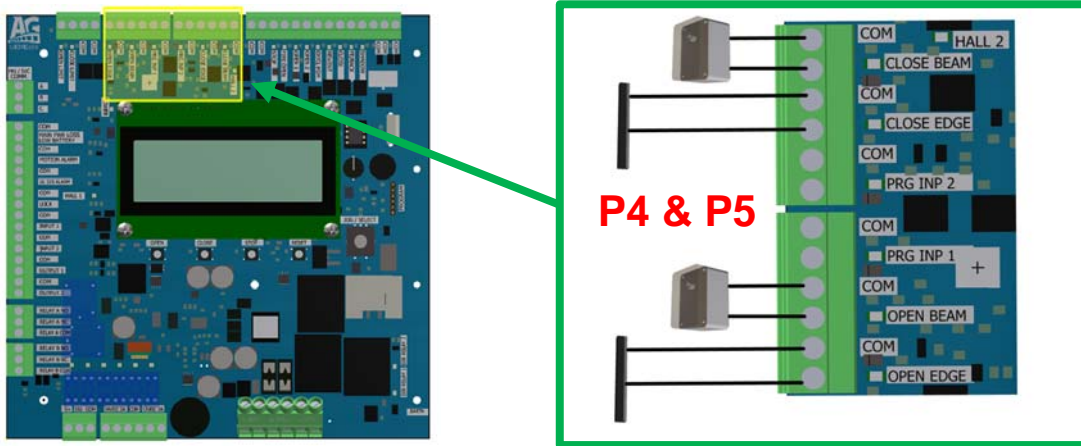

## ENTRAPMENT PROTECTION DEVICE FUNCTIONAL CHARACTERISTICS

<b>Monitored Open Edge</b>	When activated, the gate will stop, (in less than 2 seconds), and then reverse and go to a full close secured position. Gate will remain closed until it receives an “INTENDED” INPUT (Keypad/Reader/ Push Button/Free Exit) or the board is manually reset (Not from an Entrapment input).
<b>Monitored Open Beam</b>	When activated, the gate will stop, (in less than 2 seconds), and then reverse and go to a full close secured position. Gate will remain closed until it receives an “INTENDED” INPUT (Keypad/Reader/ Push Button/Free Exit) or the board is manually reset (Not from an Entrapment input).
<b>Monitored Programmable Input 1 &amp; 2</b>	Choice of Open or Close direction by Menu, choice of Edge or Beam and then 10K or 2 wire by Menu. <i>(Refer to PROGRAMMABLE INPUT FUNCTIONAL descriptions for required action.)</i>
<b>Monitored Close Edge</b>	<p>When activated the first time, the gate will stop in less than 2 seconds, and reverse to full open and allow the ‘Timer To Close’ to be activated upon open limit. Upon the second activation closing, before reaching the close limit, the gate will again stop, (in less than 2 seconds), and reverse to full open and the ‘Timer To Close’ will be deactivated. The gate will remain at full open until an “INTENDED” INPUT is activated (Keypad/Reader/Push Button/Free Exit) . The close command will close the gate and clear the hold command. An ‘Open’ command or a “Reverse” command, (not the Close Beam input) will trigger the reset of the ‘Timer To Close’ activation. Also, any of the action buttons on the control board can activate the gate, (Close button will close gate and the Open &amp; Stop buttons will reset the ‘Timer To Close’ to be active).</p> <p>Note: Upon the second activation before reaching the close limit, when the gate is in the “HOLD” condition, any input that was being maintained at the time of the second activation shall be ignored until the gate is enabled by a different input! If the CLOSE EDGE remains activated, no input will release the gate for operation.</p>
<b>Monitored Close Beam</b>	When activated, the gate shall stop in less than 2 seconds, and then reverse to full open. The ‘Timer to close’ will become active only after all inputs are clear.
<b>UL Alarm</b>	In the event the gate receives sequential obstructions, the UL Alarm will activate. To clear, verify that there are no obstructions in the movement path of the gate. Reset the gate by pressing the STOP button on the board or pulse the STOP accessory button input. If the gate keeps stopping with alarm activation, check the balance, verify that the OVER CURRENT setting is high enough to allow normal operation of the gate. On a 2490 system, make sure the LPS is functioning properly.



# OPERATIONAL RELAYS

In addition to the entrapment sensor inputs there are operational inputs for vehicle detection, communication with another gate or similar device as well as push buttons for control of various modes of operation.

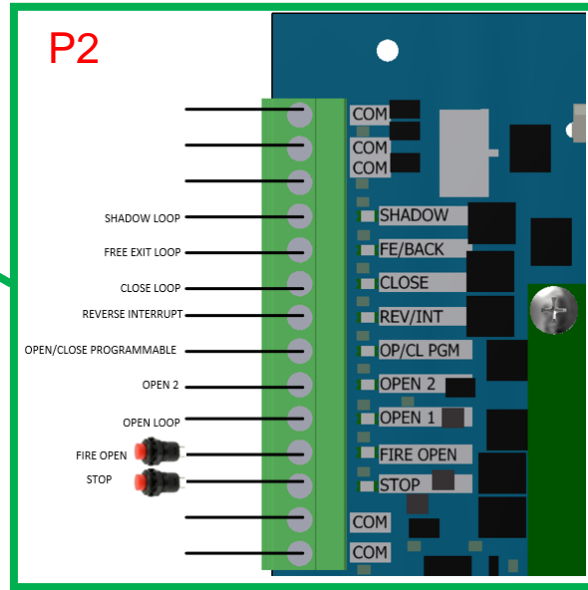
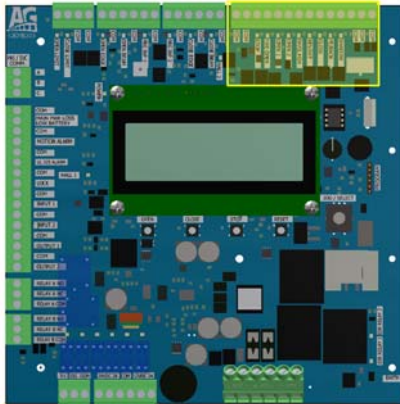

INPUT NAME	FUNCTION AFTER MOMENTARY TRIGGER	FUNCTION DURING CONTINUOUS TRIGGER
<b>Shadow Loop</b>	While at open limit, hold open, ignore once off of the open limit switch. <i>(Not common on Vertical Pivot Gate)</i>	Hold Open
<b>FE/Back (Free Exit/Back Away)</b>	Opens gate as Open1, but when signal is removed, gate is given command to close. (Close command overridden by any other open or Reverse/Interrupt command or stop command) (Primarily designed to work with FE/Back on Barrier Arms)	Starts opening movement from any position
<b>Close Loop</b>	Start closing movement from any position, Open commands can override. If gate is closing when activated, gate stops until clear and then continues to close. Close input responds on release of the input normally. Close input will hold the gate open while input is maintained with the gate in the open position. When in constant pressure mode, close input responds on initial press. <i>(Not common on Vertical Pivot Gate)</i>	If held in upward motion, no effect. If held in downward motion, gate movement is paused until released and continues downward on release
<b>Reverse/Interrupt</b>	When closing, stops and re-opens.	If held, stay open
<b>Open / Close PGM</b>	When menu option not enabled, Input = open 1 only. When enabled, input = Open 1 unless the open limit is reached, it then turns to Close. If input is held during OPEN, gate holds open. Input needs to cycle off before input can CLOSE gate.	If held it remains in its state
<b>Open 1</b>	starts opening movement from any position	starts opening from any position
<b>Open 2</b>	starts opening movement from any position	Same as above
<b>Fire Open</b>	Absolute open, until the board is hard power reset, or local reset button pushed	Locks gate open until released
<b>Stop</b>	Stops gate at any point and cancels current inputs. Inputs will be ignored until stop is released. A stop input will disable the auto-close timer	If held, no gate movement, inputs ignored.

# OPERATIONAL OUTPUTS

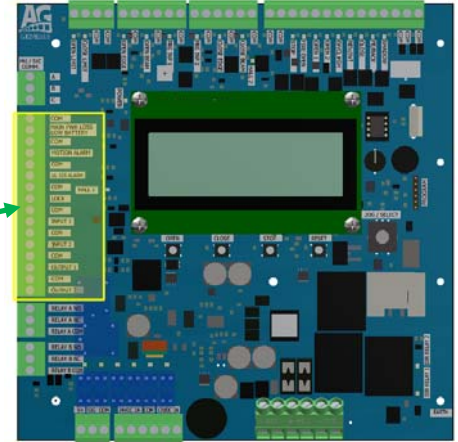
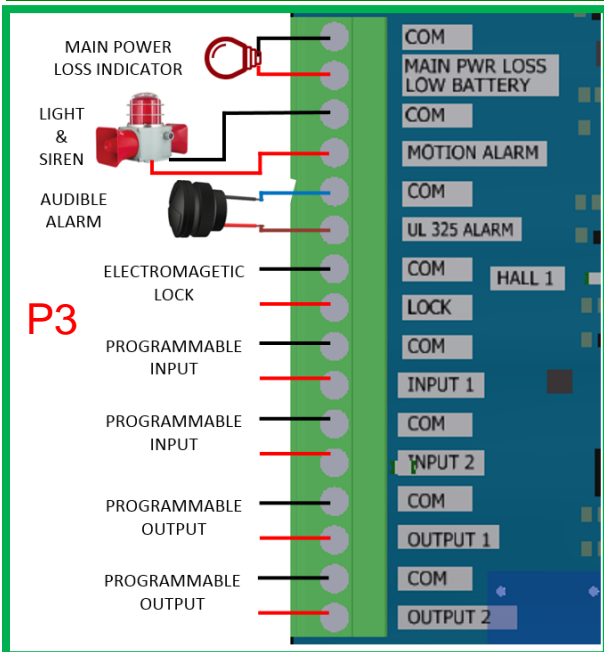

<b>Warning Light</b>	<p><b>Four States</b></p> <p><b>OFF:</b> No faults</p> <p><b>FAST Blink:</b> Low battery voltage</p> <p><b>DOUBLE PULSE Blink:</b> Loss of AC power</p> <p><b>SLOW Blink:</b> Any other fault</p> <p><i>priority for the signals are:</i></p> <ol style="list-style-type: none"> <li>1 - Low battery</li> <li>2 - Loss of AC</li> <li>3 - Any other fault</li> </ol>
<b>Motion Alarm</b>	Active for full cycle ( <b>ON-OFF</b> menu selectable). Programmable for pre-movement opening (0-5 seconds menu selectable). Programmable for pre-movement closing (0-5 seconds menu selectable).
<b>UL325 Alarm</b>	Active for conditions related to UL325 specifications
<b>Lock</b>	<p><b>Programmable/Selectable:</b></p> <p><b>Magnetic lock option</b> - Active when the gate is closed.</p> <p><b>Solenoid Interlock option</b> - Momentary activation to open the bolt that mechanically latches the gate closed.</p>
<b>Input 1</b>	<b>OPTIONS:</b> OFF, OPEN, CLOSE, Single Button, Reverse, Fire, Shadow, Auto Open, Hold Open, Emergency Secure, Auxiliary Pulse 1 & 2, Auxiliary Hold 1 & 2
<b>Input 2</b>	Same as INPUT 1
<b>Output 1 (24VDC)</b>	<b>OPTIONS:</b> OFF, Pulse on Open or Close Limit, Hold on Open or & Close Limit, Pulse on motor Open or Close, Hold on Motor Open or Close, Hold on UL Alarm, Hold on Motor Run
<b>Output 2 (24VDC)</b>	Same as Output 1

## OPERATIONAL OUTPUTS

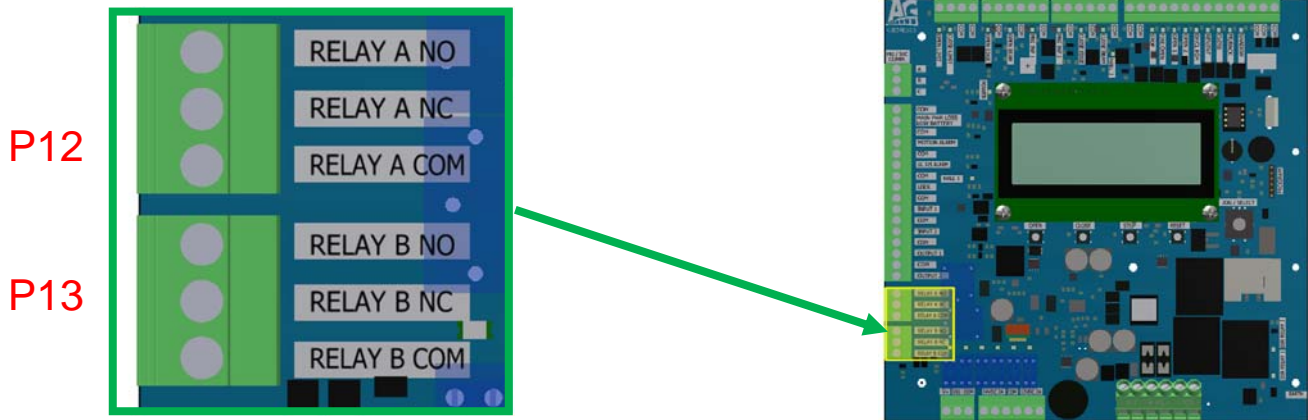

**AUX Relays A & B:** Are programmable for operation based on gate action or position. Both relays

<b>AUXILIARY RELAYS A &amp; B</b>	<p><b>OPTIONS:</b></p> <ul style="list-style-type: none"> <li>OFF</li> <li>Pulse on OPEN Limit: 2-second Relay Activation</li> <li>Pulse on CLOSE Limit: 2-second Relay Activation</li> <li>Hold on OPEN Limit: Latches Relay ON during OPEN Limit</li> <li>Hold on CLOSE Limit: Latches Relay ON during CLOSE Limit</li> <li>Pulse on Motor OPEN: 2-second Pulse when gate starts to move OPEN</li> <li>Pulse on Motor CLOSE: 2-second Pulse when gate starts to CLOSE</li> <li>Hold on Motor OPEN: Latches Relay on when gate is OPENING</li> <li>Hold on Motor CLOSE: Latches Relay ON when gate is CLOSING</li> </ul>
-----------------------------------	---

## POWER FOR EXTERNAL DEVICES

The Genesis board has (2) 24VDC outputs and (2) 12VDC outputs to power external devices. Each is fused at 2 Amps.

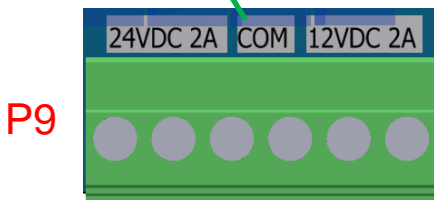
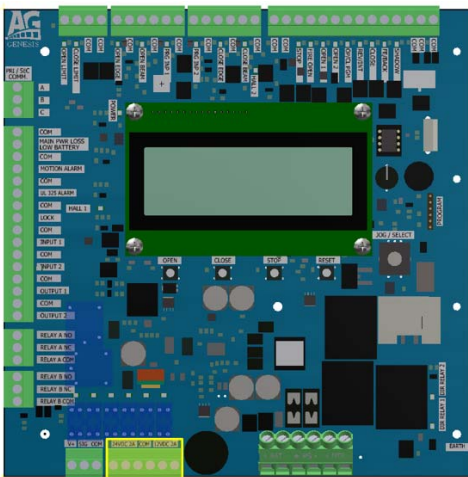

24VDC	ACCESSORY Power	(2) Fused at 2 Amps total
12VDC	ACCESSORY Power	(2) Fused at 2 Amps total

# COMMUNICATIONS AND POSITION SENSOR

Primary/Secondary communications allow for communications between gates for Dual Gate configurations.

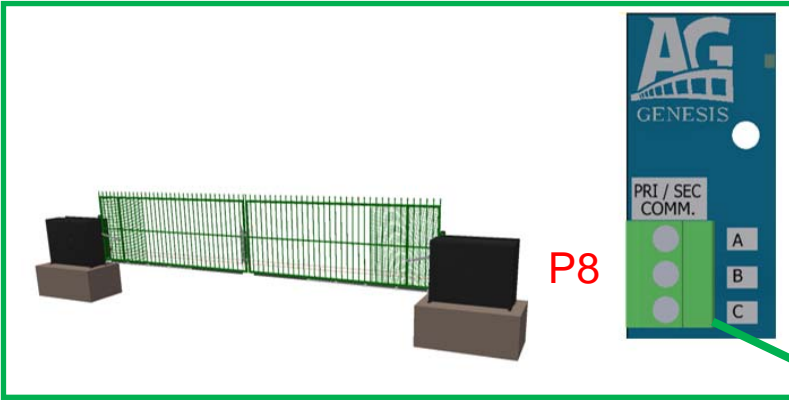

## PRIMARY/SECONDARY OR DUAL GATES

When using two gates to cover a driveway and they both need to cycle together on an open input. Connect the two boards with a 4-conductor SHIELDED 18 ga. wire (3 required, 1-spare) and set the following board parameters:

```
>Dual Gate Mode:
  Off
```

**P/S:** Set for Primary /Secondary communication. Gates need to communicate with each other to work properly.

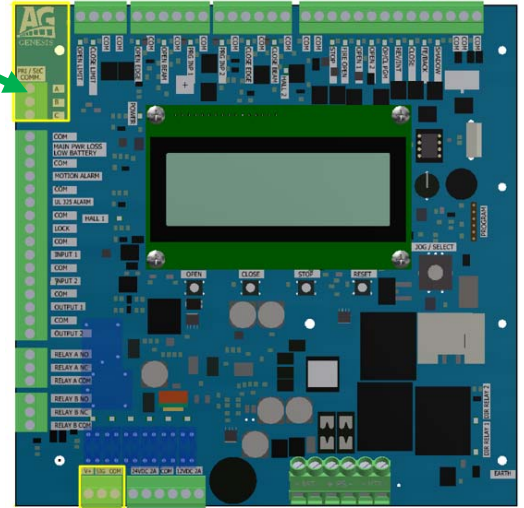

## LIMIT/POSITION SENSOR (LPS)

Your gate is equipped with a LIMIT/POSITION SENSOR. It will be properly set when it leaves the factory. If you need to adjust it, refer to the instructions below. If you need to replace, contact AutoGate.

### ADJUSTING THE LIMIT/POSITION SENSOR

```
>Op:4500 Ramp:4000
  Gate 1
```

**WARNING! This screen requires a PASSCODE to access.**

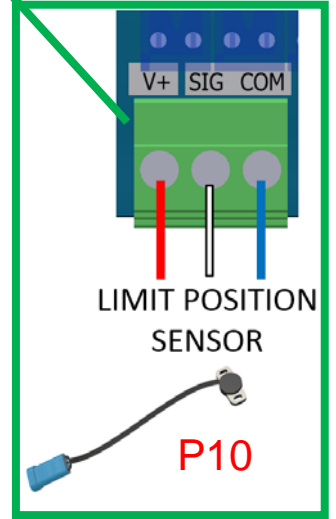

1. In programming mode, Set your cursor to the GATE (line 2) and enter (>Gate). Using the Jog knob you can slightly adjust the OPEN or CLOSE position by turning it left or right.
2. Once you have readjusted your gate position, "enter" again to back out of the Gate line and go up to the **Op:** line or down to the **Cl:** line to set your new numbers.
3. "Enter" (op or CL) and turn the jog knob to the new numbers and test your gate.

## MAINTENANCE

The basic electrical and mechanical systems require only minimum routine maintenance. The following items should be checked and serviced periodically depending on amount of use. Each item below has supporting illustrations and/or instructions in this manual. Contact AutoGate for any questions or issues. **Maintenance is important to any gate system and can affect safety, warranty, quality operation, and life-cycle of the system.**

ITEM	RECOMMENDED MAINTENANCE
Grease Linkage Assembly (“LUBRIPLATE ‘R’ LOW TEMP” Grease)	10,000 cycles or 6 months
Grease all bearings: two (2) Operator Arm, four (4) Bullwheel Shafts	10,000 cycles or 6 months
Grease Chain Tension Bolt and Lube Chain & lightly coat springs (Use a non-evaporating cable and chain spray)	10,000 cycles or 6 months
Check belts for wear and tightness. (See page 44 for instructions)	Every 6 months
Charge voltage for batteries should be 27.5 VDC with batteries disconnected check at battery in maintenance menu.	Every 6 months
Check battery water level, use distilled water only (Not required on maintenance-free or AGM style batteries)	Every 6 months
Clean snow/ice off of gate (Balanced correctly, gate will temporarily tolerate an additional 10 lb. of wt.)	As needed
Clean lenses on Photoelectric sensors/beams or Reflectors	As needed
Lubricate (Graphite Oil) all door latch, lock cylinders and mechanisms	Every 6 months
Check and verify proper operation of all <b>External monitored</b> entrapment protection devices.	Every month
Check and verify proper operation of the <b>Internal</b> (TYPE A) entrapment protection device (LPS) by walking to the end of the gate and stop the gate, it should reverse.	Every month
Check gate balance (see page 16)	Four months after install, then annually
Check to make sure all WARNING signs are still displayed	Every month

## BELT CHANGING INSTRUCTIONS

Changing the belts on an AutoGate Vertical Pivot operator is easy by following the step by step procedure outlined below. As always, we are only a phone call away should you need assistance at 800-944-4283.

1. Remove the **(4) Tek Screws** on the **Top Panel** using a 5/16" nut driver, remove and set aside.
2. Remove the **STIFFENER PLATE (#1)** from the **POSITION SENSOR bracket**. This allows a space to remove belts.
3. Release the **MOTOR DRIVE BELT (#2)** tension by loosening the **(4) 3/8" CARRIAGE BOLT nuts** securing the **GEAR MOTOR bracket (#3)** to the **SIDE SLIDE plates (#4)** with a 9/16" wrench. Now using a 9/16" wrench, back off the **(2) Gear Motor FORCING screws (#5)** so that only 1" remains through the coupling nut.
4. Slide the **GEAR MOTOR assembly** to create slack in the belts.
5. On the center of the pulleys. Loosen the **FLANGE BEARING bolts (#6)** about one turn that secure the shaft bearings using a 15/16" wrench.
6. Loosen the **MIDDLE FORCING screw (#7)** which is applying tension on the **GATE DRIVE belts (#8)** by using a 15/16" wrench. This too needs to be fully loosened to allow enough room to remove the belts.
7. Remove old belts and install new belts loosely.
8. Apply snug pressure to the **MOTOR DRIVE belts** by using the **(2) GEAR MOTOR FORCING screws**. This should also snug the **GATE DRIVE belts**. **Do not overtighten!**
9. Thread the **MIDDLE FORCING screw** to finger tight.
10. Re-Assemble the **STIFFNER PLATE** to the **POSITION SENSOR bracket**.
11. Operate the gate up and down for (5) time to seat the belts.
12. Tighten the **MIDDLE FORCING screw** to tighten the **GATE DRIVE belts**. **SEE PAGE 3 FOR BELT TENSION INFORMATION**
13. Tighten the **FLANGE BEARING bolts** on the middle set of pulleys.
14. Tighten the **GEAR MOTOR FORCING screw** **SEE PAGE 3 FOR BELT TENSION INFORMATION**
15. Tighten the **(4) CARRIAGE bolts** to secure the **GEAR MOTOR bracket** to the **SIDE SLIDE plates**.
16. Operate the gate up and down 5-10 times to check for proper operation.
17. Replace the **Top Panel** using the (4) **Tek screws**.

## BELT TIGHTENING INSTRUCTIONS

- |                     |                              |
|---------------------|------------------------------|
| 1. Stiffener Plate  | 5. Gear Motor Forcing Screws |
| 2. Motor Drive Belt | 6. Flange Bearing Bolts      |
| 3. Gear Motor       | 7. Middle Forcing Screw      |
| 4. Side Slide       | 8. Gate Drive Belts          |

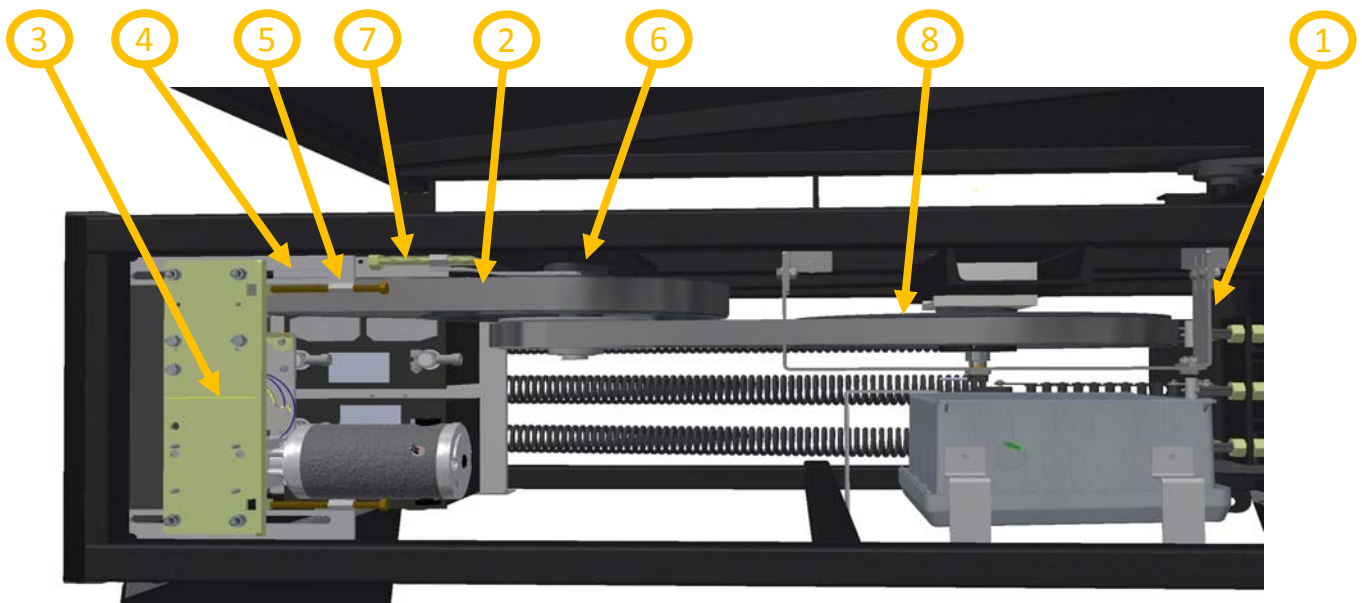

## SPRING CHANGING INSTRUCTIONS



**WARNING:** SPRINGS ARE UNDER A TREMENDOUS LOAD. TAKE EXTREME CAUTION WHEN REMOVING AND REPLACING THEM.

**TOOLS REQUIRED:** 5/16" (Nut Driver), 1/2", 1 1/8", 1 5/16" Open End Wrenches

### STEPS:

1. For ease of access, remove the door and end panel nearest the gate.
2. Disable the photoelectric sensor/beam if equipped.
3. Remove any upper "T" bolts completely and loosen the slide assembly screws.
4. Loosen the top adjusting nut of the slide assembly. Thread the nut up to within four (4") inches of the top of slide mechanism.
5. You will now raise the gate. (**DO NOT** release the disengage lever!) Initiate the gate to open, immediately move to the gate and help raise it open, once the slide moves up, hold on the bottom rail of the gate until fully open. The gate may bounce slightly, there will be a loud bang but no damage will occur.
6. Turn Off AC/DC Power before gate "times out" and tries to close. Insert T/M Pin.
7. Using a 1 5/16 wrench, loosen and remove the chain tension bolt with the damaged spring.
8. Replace damaged spring
9. Replace chain tension bolt. **NOTE:** Grease fitting must point down! Tighten bottom nut. **NOTE:** Chain **MUST** remain level and not twisted once tightened.
10. Remove T/M pin and restore AC/DC power.
11. Lowering the gate. Initiate the gate to close and at the same time, assist the gate down by pulling on the bottom rail of the gate. The slide will move down and another loud bang as the gate is lowered.
12. Turn off AC/DC power.
13. Thread the slide nut back down to the slide assembly and tighten.
14. Replace the T-Bolts to their original location and tighten and tighten the slide assembly screws.
15. Restore AC/DC power and hook photoelectric sensor/beam back up.
16. Cycle gate.

17. Spray all springs with a chain lube to prevent corrosion.

18. Grease Chain Tension bolts, Linkage Arm & Bearings

**RECOMMENDED:** Always check and adjust the balance after any spring change. Refer to balancing instructions at [www.AutoGate.com](http://www.AutoGate.com) or the instructions on Page 16

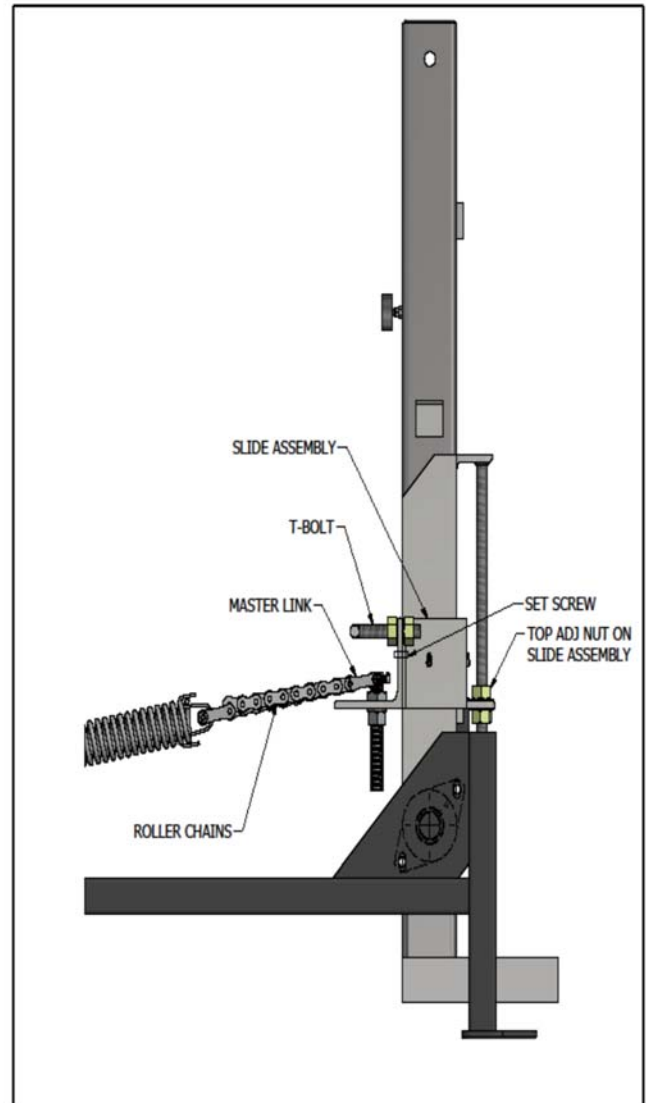

# BALANCING

## TESTING AMPERAGE

1. Connect AMP meter in series by removing the wire nut from the **RED** motor lead.
2. Cycle gate up and down recording the highest amperage in the space provided and adjust in necessary. highest UP and DOWN readings should not exceed a 1 AMP difference. For example: if your highest reading is 6.5 UP and 6.0 DOWN, that would be acceptable. Unacceptable would be 3.1 UP and 8.0 down.

## ADJUSTING:

1. Loosen the set screws on the Slide Assembly as well as the 1 1/8" nuts on both sides (top & bottom) of the Slide Assembly Angle.
2. Only adjust the nuts 3 to 4 turns (1/4") at a time and check your amperage readings after each adjustment.  
NOTE: your Amps in the OPEN mode should be approximately .5 (1/2) amp higher than the CLOSE amperage.
3. If the gate opens too slow and is drawing high Amps, raise the Slide Assembly and recheck. If the gate will NOT close, lower the Slide Assembly and re-check. If your gate stalls in either direction, you have over-adjusted. Back off the last adjustment and re-check.
4. If the gate is slow starting to close from the open position, increase the length of the T-Bolt (s).
5. Tighten Set Screws and 1 1/8" nuts.

